

Gold DBWhistle Digital Servo Drive Installation Guide CAN and EtherCAT

Customized by www.monotion.com



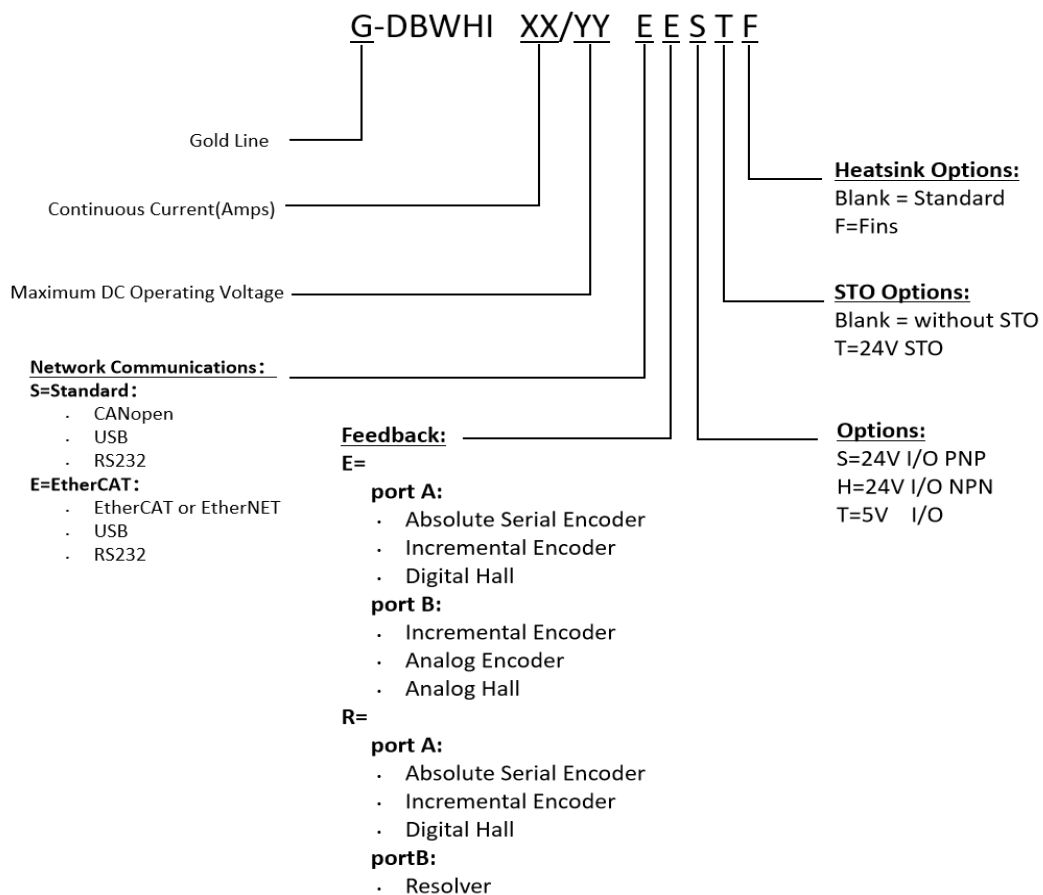
Notice

This guide is delivered subject to the following conditions and restrictions:

- This guide contains proprietary information belonging to Elmo Motion Control Ltd. Such information is supplied solely for the purpose of assisting users of the Gold DBWhistle servo drive in its installation.
- The text and graphics included in this manual are for the purpose of illustration and reference only. The specifications on which they are based are subject to change without notice.
- Information in this document is subject to change without notice.

Document no. MAN-G-DBWHI
 Copyright © 2020
 Elmo Motion Control Ltd.
 All rights reserved.

Catalog Number





Catalog Number.....	2
Chapter1: This Installation Guide.....	5
Chapter2: Safety Information.....	5
2.1. Warnings.....	8
2.2. Cautions.....	8
2.3. Warranty Information.....	8
Chapter3: Product Description.....	9
Chapter4: Technical Information.....	10
4.1. Physical Specifications.....	10
4.2. 100V Models Technical Data.....	10
4.3. 200V Models Technical Data.....	11
4.4. Product Features.....	12
4.5. Environmental Conditions.....	13
Chapter5: Standards.....	14
5.1. CE Declaration.....	14
Chapter6: Installation.....	14
6.1. Unpacking the Drive Components.....	14
6.2. Mounting the Gold DBWhistle.....	15
6.3. Gold DBWhistle Connection Diagrams.....	16
Chapter7: Wiring.....	18
7.1. Basic Recommendations.....	19
7.1.1. General.....	19
7.1.2. Feedback Cable Port A and Port B Connector.....	20
7.1.3. Feedback Cable Port C Connector.....	21
7.1.4. IO Cable Connector.....	21
7.1.5. STO Cable Connector.....	22
7.2. Motor Power.....	23
7.2.1. Motor Power Connections.....	24
7.3. Main Power.....	25
7.3.1. Main Power.....	25
7.4. Feedback Connector.....	26
7.4.1. Port A.....	27
7.4.1.1. Incremental Encoder.....	27
7.4.1.2. Absolute Serial Encoder.....	28
7.4.1.3. Hall Sensors.....	30
7.4.2. Port B & Port C.....	32
7.4.2.1. Incremental Encoder.....	33
7.4.2.2. Interpolated Analog Encoder.....	34
7.4.2.3. Resolver.....	35
7.4.3. Port C – Emulated Encoder Output.....	36
7.5. Digital Inputs , Digital Outputs,Analog Input and RS232.....	60
7.5.1. Digital Inputs.....	62
7.5.2. Digital Outputs.....	61
7.5.3. Analog Input.....	67
7.5.4. RS232.....	68
7.6. EtherCAT Communications Version.....	69
7.6.1. EtherCAT IN/Ethernet Pinouts.....	69
7.6.2. EtherCAT OUT Pinouts.....	70
7.6.3. EtherCAT Wiring.....	60
7.6.4. EtherCAT Link Indicators.....	60
7.6.5. EtherCAT Status Indicator.....	61
7.7. CAN Communications Version.....	61
7.7.1. CAN Wiring.....	62
7.7.2. USB 2.0 Communication (for EtherCAT model only).....	63
Chapter8: Powering Up.....	64
8.2. Initializing the System.....	64
8.3. Heat Dissipation.....	65
8.3.1. Heat Dissipation Data.....	65
8.4. How to Use the Charts.....	68
Chapter9: Dimensions.....	69



Chapter1: This Installation Guide

This installation Guide details the technical data, pinouts, and power connectivity of the Gold DBWhistle. For a comprehensive detailed description of the functions and connections of the drive, refer to the Gold Board Level Module Hardware Manual.

Chapter2: Safety Information

In order to achieve the optimum, safe operation of the Gold DBWhistle, it is imperative that you implement the safety procedures included in this installation guide. This information is provided to protect you and to keep your work area safe when operating the Gold DBWhistle and accompanying equipment.

Please read this chapter carefully before you begin the installation process.

Before you start, ensure that all system components are connected to earth ground. Electrical safety is provided through a low-resistance earth connection.

Only qualified personnel may install, adjust, maintain and repair the servo drive. A qualified person has the knowledge and authorization to perform tasks such as transporting, assembling, installing, commissioning and operating motors.

The Gold DBWhistle contains electrostatic-sensitive components that can be damaged if handled incorrectly. To prevent any electrostatic damage, avoid contact with highly insulating materials, such as plastic film and synthetic fabrics. Place the product on a conductive surface and ground yourself in order to discharge any possible static electricity build-up.

To avoid any potential hazards that may cause severe personal injury or damage to the product during operation, keep all covers and cabinet doors shut.

The following safety symbols are used in this and all Elmo Motion Control manuals:



Warning:

This information is needed to avoid a safety hazard, which might cause bodily injury or death as a result of incorrect operation.



Caution:

This information is necessary to prevent bodily injury, damage to the product or to other equipment.



Important:

Identifies information that is critical for successful application and understanding of the product.



2.1. Warnings

- To avoid electric arcing and hazards to personnel and electrical contacts, never connect/disconnect the servo drive while the power source is on.
- Power cables can carry a high voltage, even when the motor is not in motion. Disconnect the Gold DBWhistle from all voltage sources before servicing.
- The high voltage products within the Gold Line range contain grounding conduits for electric current protection. Any disruption to these conduits may cause the instrument to become hot (live) and dangerous.
- After shutting off the power and removing the power source from your equipment, wait at least 3 minutes before touching or disconnecting parts of the equipment that are normally loaded with electrical charges (such as capacitors or contacts). Measuring the electrical contact points with a meter, before touching the equipment, is recommended.



2.2. Cautions

- The maximum DC power supply connected to the instrument must comply with the parameters outlined in this guide.
- When connecting the Gold DBWhistle to an approved control supply, connect it through a line that is separated from hazardous live voltages using reinforced or double insulation in accordance with approved safety standards.
- Before switching on the Gold DBWhistle, verify that all safety precautions have been observed and that the installation procedures in this manual have been followed.
- Make sure that the Safe Torque Off is operational

2.3. Warranty Information

The products covered in this manual are warranted to be free of defects in material and workmanship and conform to the specifications stated either within this document or in the product catalog description. All Elmo drives are warranted for a period of 12 months from the date of shipment. No other warranties, expressed or implied — and including a warranty of merchantability and fitness for a particular purpose — extend beyond this warranty.



Chapter3: Product Description

The Gold DBWhistle is an advanced high power density servo drive, delivering up to **5.6 kW power** in a 330 cc (20.13 in³) compact package (120 x 86 x 26 mm or 4.7" x 3.38" x 1.02").

This advanced, high power density servo drive provides top performance, advanced networking and built-in safety, as well as a fully featured motion controller and local intelligence. Power to the Gold DBWhistle is provided by a DC power source which is isolated from the Mains. The Gold DBWhistle can operate with single or dual power supplies. If separation between the main DC power source and a control supply is required, then a control supply (isolated from the Mains) is required.

The drive can operate as a stand-alone device or as part of a multi-axis system in a distributed configuration on a real-time network.

The Gold DBWhistle drive is easily set up and tuned using the Elmo Application Studio (EASII) software tools. As part of the Gold product line, it is fully programmable with the Elmo motion control language. For more information about software tools refer to the Elmo Application Studio (EASII) User Guide.

The Gold DBWhistle is available in a variety of models. There are a number of possible options; multiple power rating, various communications, and feedback.



Chapter4: Technical Information

Note:

It should be noted that for all models, the Max Output current is guaranteed for $T_{\text{Heat-Sink}} < 85^{\circ}\text{C}$

4.1. Physical Specifications

Feature	Units	All Types
Weight	g (oz)	259g (9.14oz)
Dimension	mm (in)	(120 x 86 x 26 mm or 4.7" x 3.38" x 1.02")
Mounting method		Wall Mount / Book Shelf

4.2. Technical Data

Feature	Units	5/100	10/100	20/100
Minimum supply voltage	VDC	12		
Nominal supply voltage	VDC	85		
Maximum supply voltage	VDC	95		
Maximum continuous power output	W	400	800	1600
Efficiency at rated power (at nominal conditions)	%	>99		
Maximum output voltage		>95% of DC bus voltage at f=22kHz		
Ic, Amplitude sinusoidal/DC continuous current	A	5	10	20
Sinusoidal continuous RMS current limit (Ic)	A	3.5	7	14.1
Peak current limit	A	2xIc		

Table 1: 100V Models Technical Data



4.3. 200V Models Technical Data

Feature	Units	6/200	9/200
Minimum supply voltage	VDC	12	
Nominal supply voltage	VDC	170	
Maximum supply voltage	VDC	195	
Maximum continuous power output	W	960	1450
Efficiency at rated power (at nominal conditions)	%	>99	
Maximum output voltage		>95% of DC bus voltage at f=22kHz	
I _c , Amplitude sinusoidal/DC continuous current	A	6	9
Sinusoidal continuous RMS current limit (I _c)	A	4.2	6.3
Peak current limit	A	2xI _c	

Table 2: 200V Models Technical Data



4.4. Product Features

Main Feature	Details	Presence / No.
STO	5V Logic Level, Opto isolated from the Control section	√
Digital Input Option	5V Logic Level (Internally connected to COMRET)	6
Digital Output Option	5V logic (Internally connected to COMRET)	2
	3.3V logic (Internally connected to COMRET)	2
Analog Input	Differential ±10V	1
	Single Ended	1
Feedback	Standard Port A, B, & C	√
Communication Option	USB (only for EtherCAT version)	√
	EtherCAT <i>or</i>	√
	CAN	√
	RS232 TTL level	√
	Standard RS232	√



4.5. Environmental Conditions

You can guarantee the safe operation of the Gold DBWhistle by ensuring that it is installed in an appropriate environment.

Feature	Details
Operating ambient temperature in compliance with STO standards	0 °C to 40 °C (32 °F to 104 °F)
Operating ambient temperature according to IEC60068-2-2	0 °C to 50 °C (32 °F to 122 °F) in compliance with UL standards
Storage temperature	-20 °C to +85 °C (-4 °F to +185 °F)
Maximum non-condensing humidity according to IEC60068-2-78	95%
Maximum Operating Altitude	2,000 m (6562 feet) It should be noted that servo drives capable of higher operating altitudes are available on request.
Mechanical Shock according to IEC60068-2-27	15g / 11ms Half Sine
Vibration according to IEC60068-2-6	5 Hz ≤ f ≤ 10 Hz: ±10mm 10 Hz ≤ f ≤ 57 Hz: 4G 57 Hz ≤ f ≤ 500 Hz:5G



Chapter5: Standards

Refer to the complete Standards list detailed and available on the internet at:

<https://www.elmomc.com/capabilities/standards-compliance/gold-family/>

5.1. CE Declaration

Refer to the complete EC Declaration of Conformity available on the internet at:

https://www.elmomc.com/wp-content/uploads/dlm_uploads/2018/05/Gold-Line-CE-Declaration-of-Conformity.pdf.

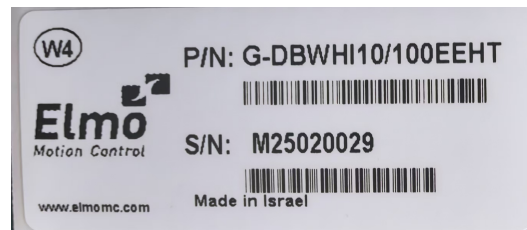
Chapter6: Installation

The Gold DBWhistle must be installed in a suitable environment and properly connected to its voltagesupplies and the motor.

6.1. Unpacking the Drive Components

Before you begin working with the Gold DBWhistle, verify that you have all of its components, as follows:

- The Gold DBWhistle servo drive
- The Elmo Application Studio (EASII) software and software manual
- The Gold DBWhistle is shipped in a cardboard box with Styrofoam protection.



To unpack the Gold DBWhistle:

1. Carefully remove the servo drive from the box and the Styrofoam.
2. Check the drive to ensure that there is no visible damage to the instrument. If any damage has occurred, report it immediately to the carrier that delivered your drive.
3. To ensure that the Gold DBWhistle you have unpacked is the appropriate type for your requirements, locate the part number sticker on the side of the Gold DBWhistle. It looks like this:
4. Verify that the Gold DBWhistle type is the one that you ordered, and ensure that the voltage meets your specific requirements.

The part number at the top provides the type designation. Refer to the appropriate part number in the section Catalog Number at the beginning of the installation guide



6.2. Mounting the Gold DBWhistle

The Gold DBWhistle has been designed for two standard mounting options:

- Wall Mount along the back (can also be mounted horizontally on a metal surface)
- Book Shelf along the side

M4 round head screws, one through each opening in the heat sink, are used to mount the Gold DBWhistle (see the diagram below).

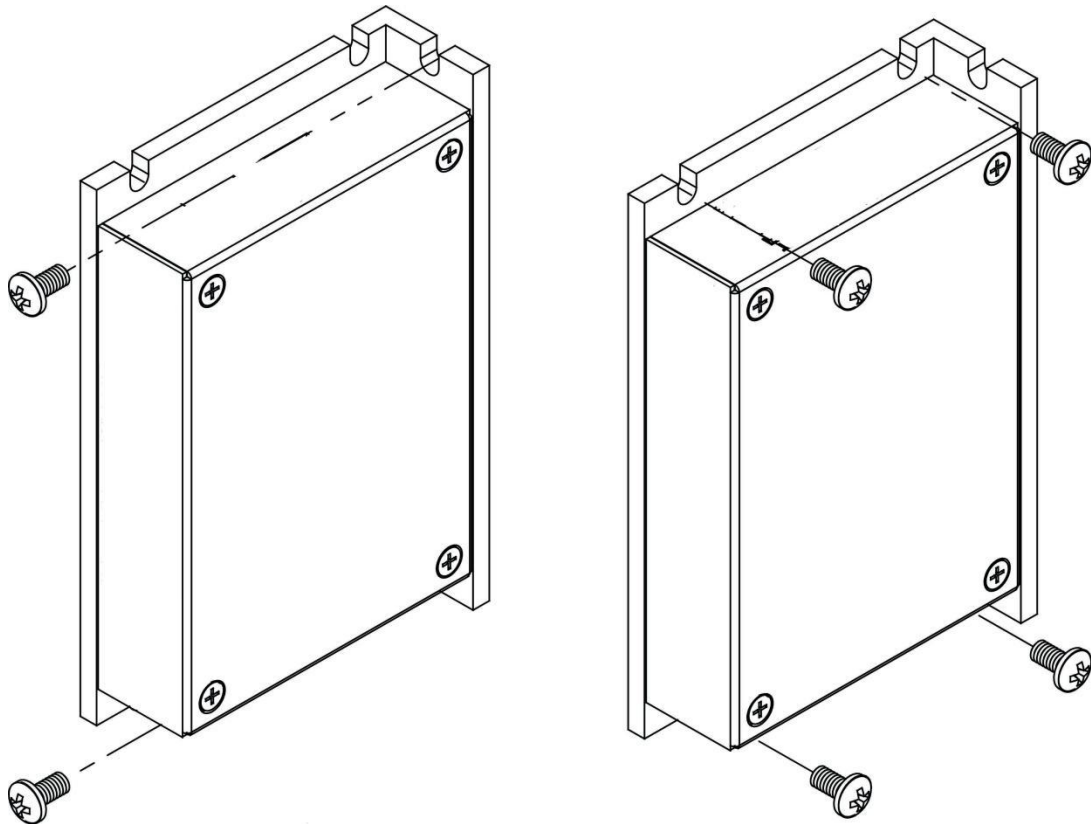
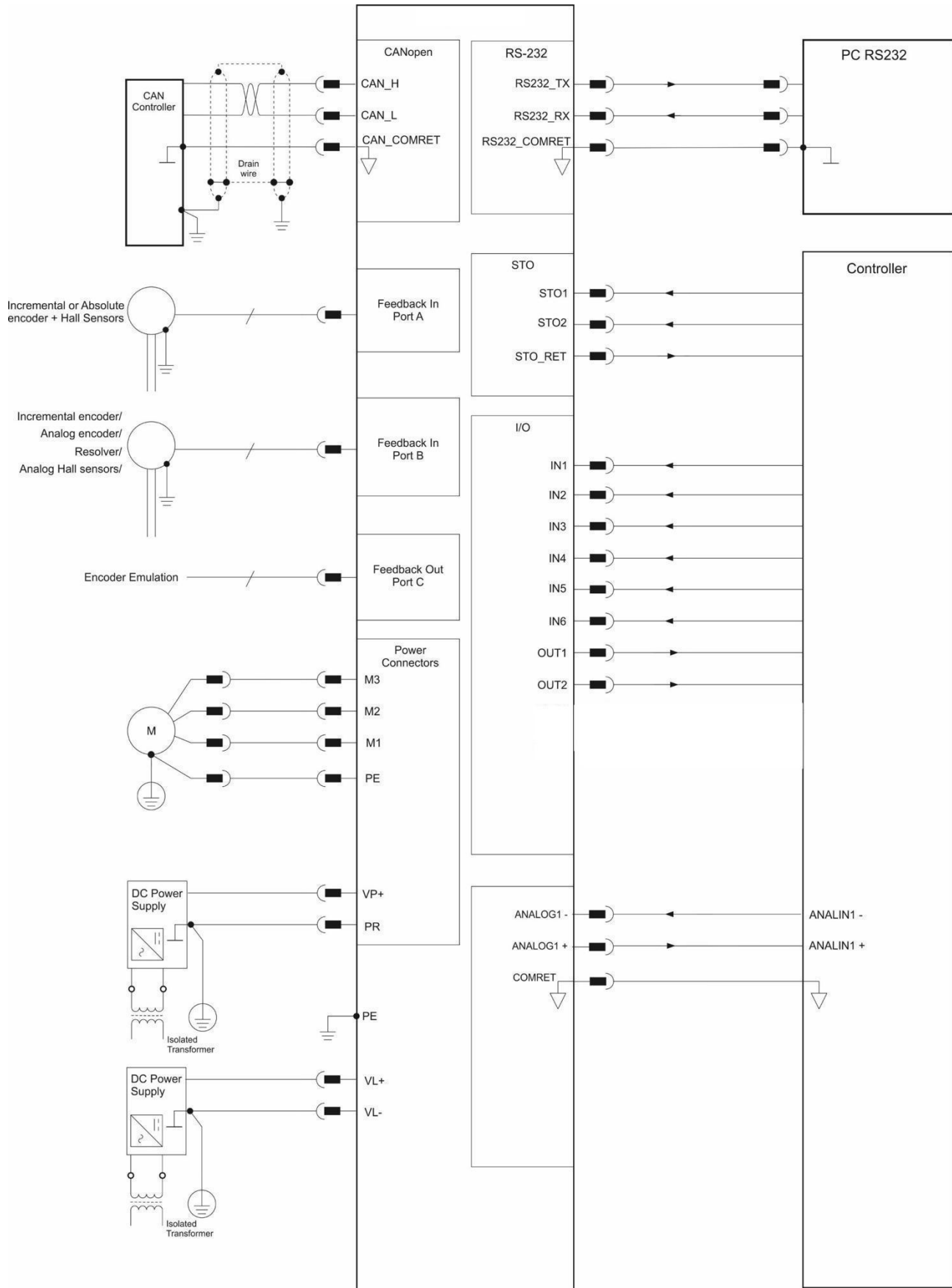


Figure 1: Mounting the Gold DBWhistle

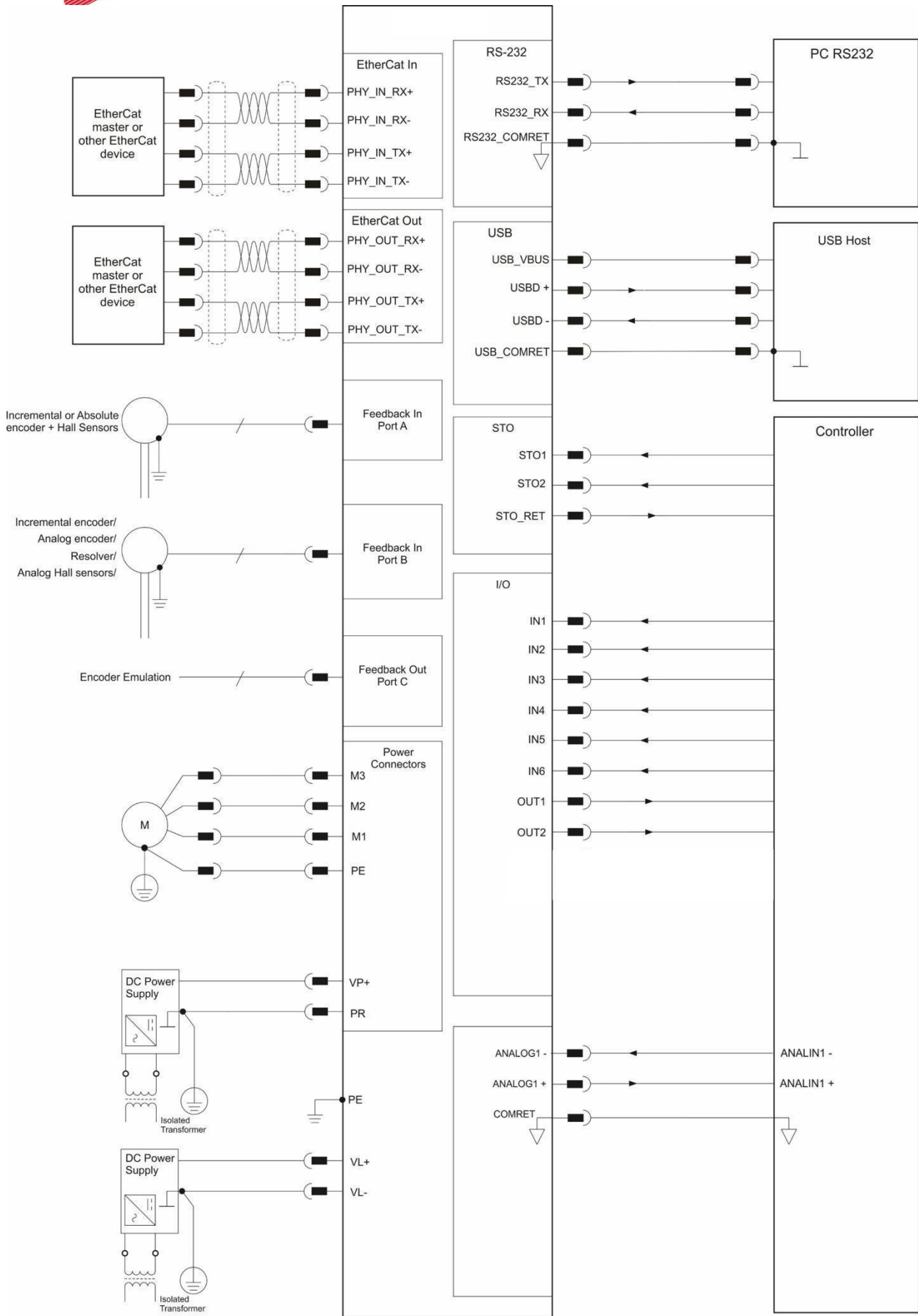


6.3. Gold DBWhistle Connection Diagrams



G-TWI-506B

Figure 2: The Gold DBWhistle CAN Connection Diagram






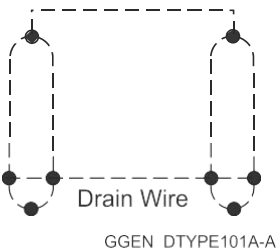
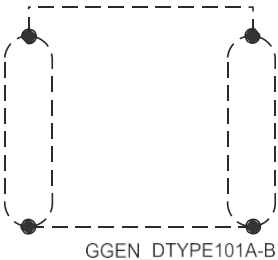
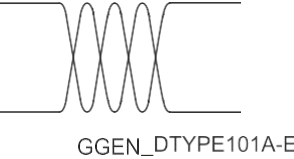
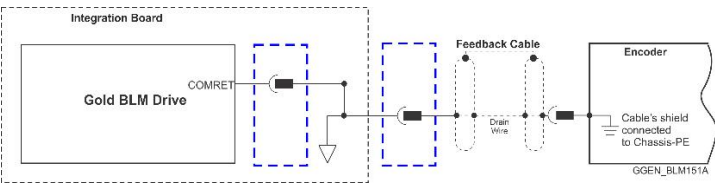
G-TWI-507B

Figure 3: The Gold DBWhistle EtherCAT Connection Diagram



Chapter7: Wiring

The following table legend describes the wiring symbols detailed in all installation guides. All the wiring diagrams show wiring for D-TYPE connectors

Wiring Symbol	Description
	Earth connection (PE)
	Protective Earth Connection
	Common at the Controller
	<p>Shielded cable with drain wire.</p> <p>The drain wire is a non-insulated wire that is in direct contact with the braid (shielding).</p> <p>Shielded cable with drain wire significantly simplifies the wiring and earthing.</p>
	Shielded cable braid only, without drain wire.
	Twisted-pair wires
	<p>Encoder Earthing.</p> <p>The cable`s shield is connected to the chassis (PE) in the connector.</p> <p>Earthing the Encoder and connecting the Earth (PE) to the drive COMRET is mandatory to insure reliable operation, high noise immunity and rejection of voltage common mode interferences.</p>



7.1. Basic Recommendations

7.1.1. General

1. Use shielded cables. For best results, the cable should have an aluminum foil shield covered by copper braid, and should contain a drain wire.
2. Use 24, 26 or 28 AWG twisted-pair shielded with drain wire cables.
3. Keep the cable as short as possible.
4. Do not mount the power cables of the motor and power bus in the proximity of the control and feedback cables.
5. Ensure that in normal operating conditions, the “earth connection” wires and shield of the control cables carry no current. The only time these conductors carry current is under abnormal conditions, when electrical equipment has become a potential shock or fire hazard while conducting external EMI interferences directly to ground, in order to prevent them from affecting the drive. Failing to meet this requirement might result in drive/controller/host failure.
6. After completing the wiring, carefully inspect all wires to ensure tightness, good solder of joints
7. and general safety.

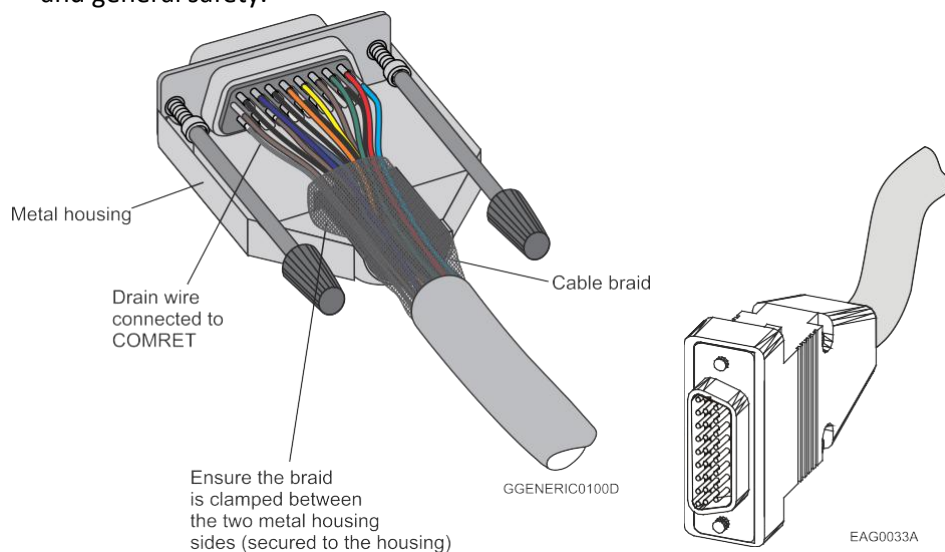


Figure 3: D-Type Cable Assemblies

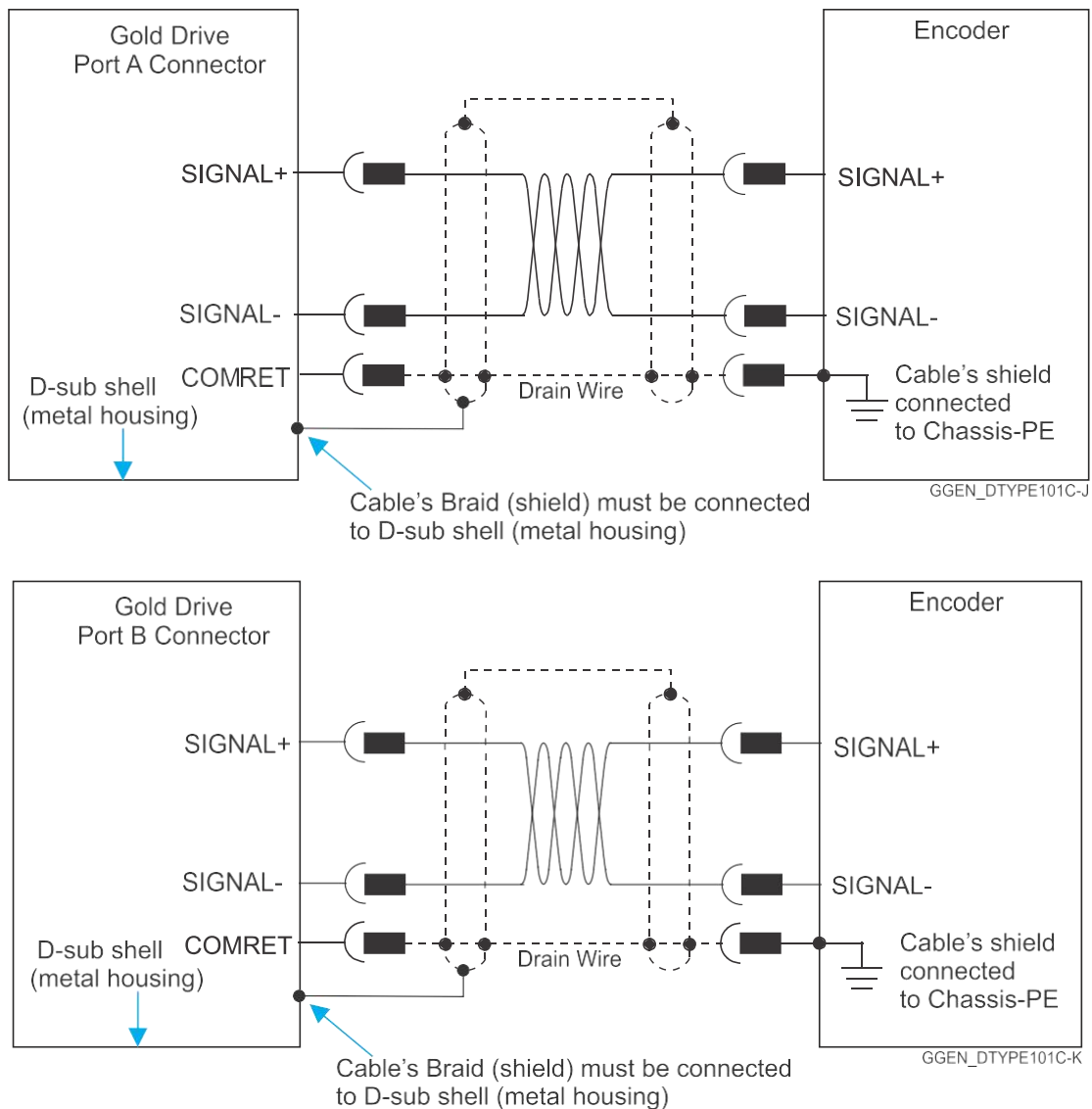
8. Use only a D-Sub connector with a metal housing (Figure 4).
9. Make sure the braid shield is in tight contact with the metal housing of the D-type connector (Figure 4).



7. 1. 2. Feedback Cable Port A and Port B Connector

- 1 . On the motor side connections, ground the shield to the motor chassis.
- 2 . At least One COMRET (Common Return) must be connected to the PE. Implement the following steps to connect the COMRET to the PE:
 - a. At the drive, connect the feedback drain wire to one of the COMRET terminals in the D-Type feedback connector (Figure 5).
 - b. At the motor, connect the feedback cable drain wire to the GND motor chassis terminal of the feedback connector.The drawings below display two earth connections

Figure 5: Feedback Port A and B Cable Assemblies





7. 1. 3. Feedback Cable Port C Connector

1. At the controller side connections, follow the controller manufacturer's recommendations concerning the shield.
2. The connection of the Drain wire to the Port C is not mandatory.

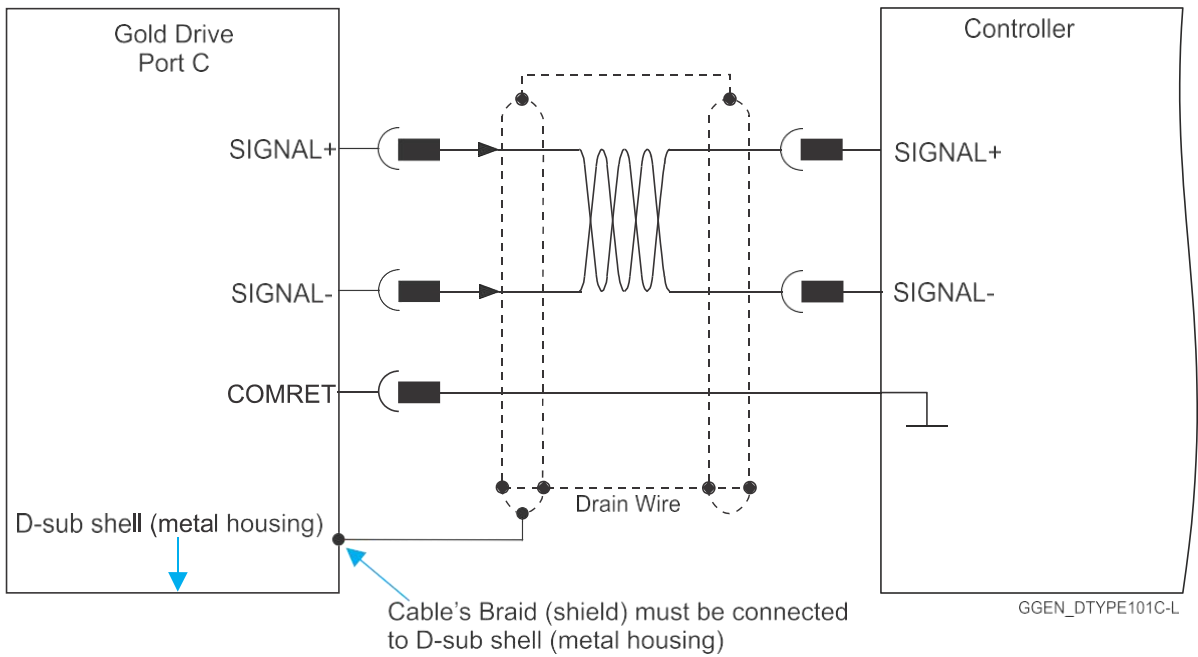


Figure 4: Feedback Port C Cable Assemblies

7. 1. 4. IO Cable Connector

It is recommended to use shielded cable, but is not mandatory.

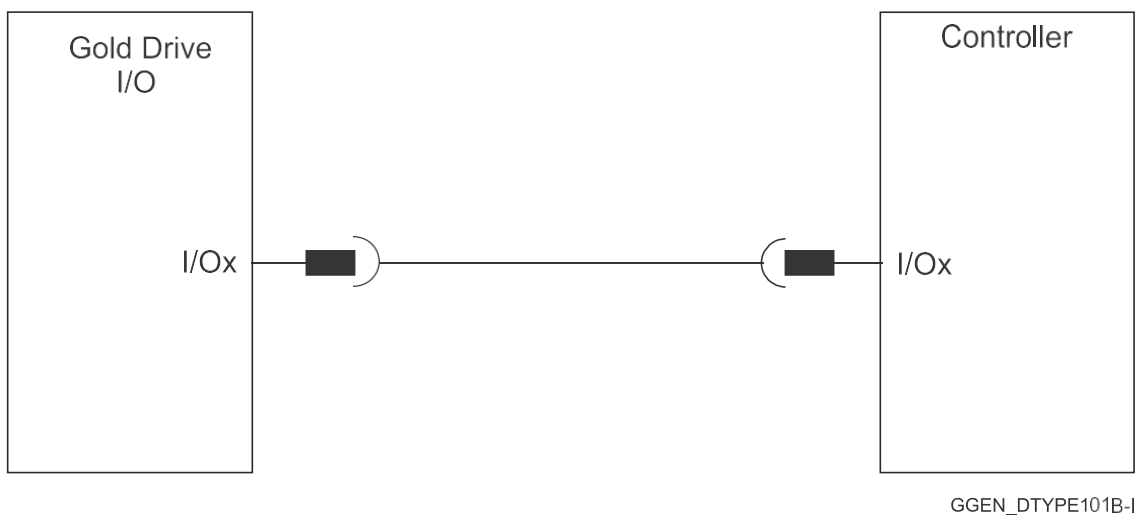
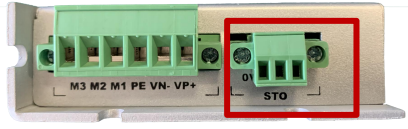


Figure 5: Feedback IO Cable Assemblies



7. 1. 5. STO Cable Connector

Pin	Singnal	Function	Pin Positions
0V	STO_RET	STO signal return	
1	STO1	STO1 input (default 24V)	
2	STO2	STO2 input (default 24V)	

It is recommended to use shielded cable

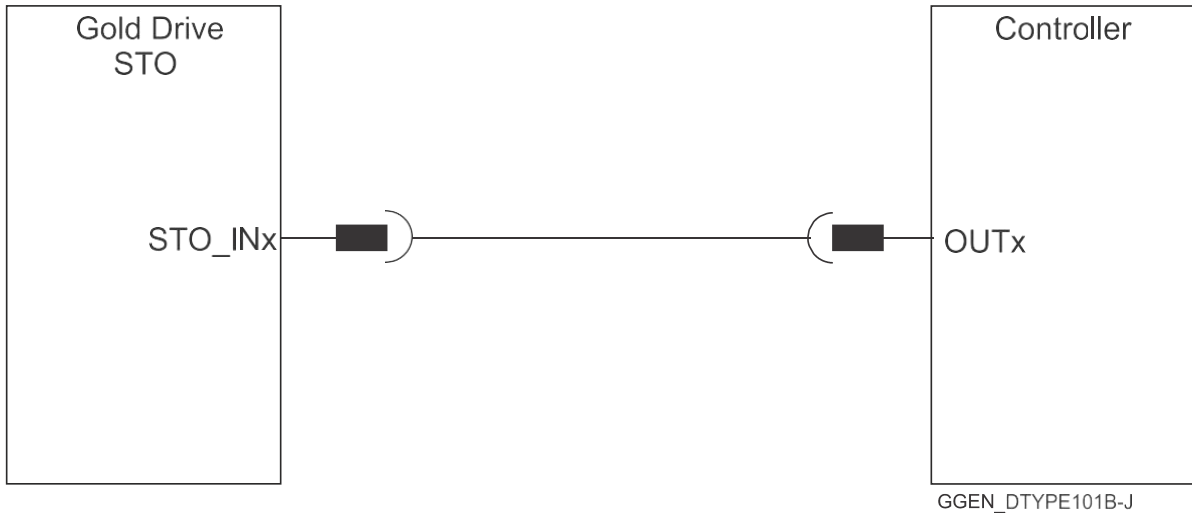


Figure 6: STO Cable Assemblies



7.2. Motor Power

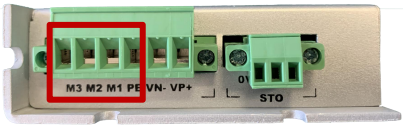
Pin	Function	Cable		Pin Positions
		Brushless Motor	Brushed DC Motor	
PE	Connection earth	Motor	Motor	
M1	Motor phase	Motor	N/C	
M2	Motor phase	Motor	Motor	
M3	Motor phase	Motor	Motor	

Table 4: Motor Connector

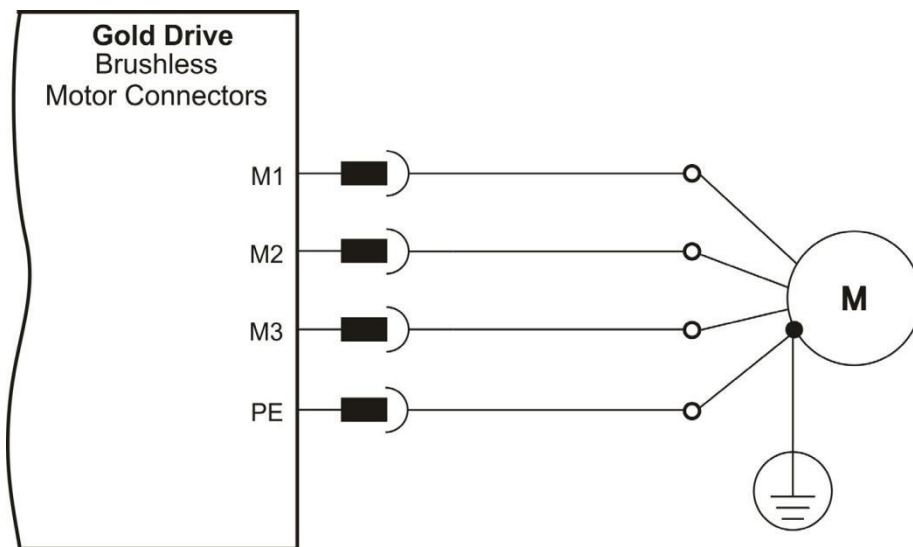


Figure 4: Brushless Motor Power Connection Diagram

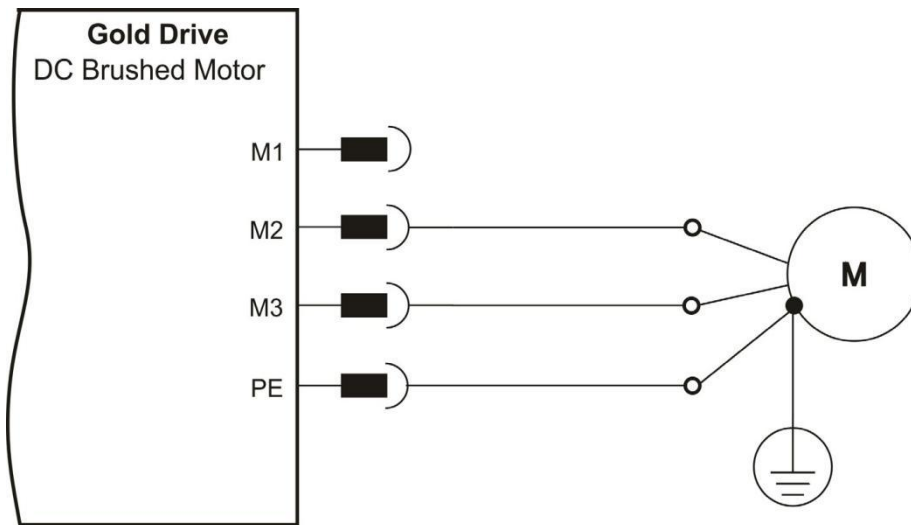


Figure 5: Brushed Motor Power Connection Diagram

7. 2. 1. Motor Power Connections

1. Ensure that the motor chassis is properly earthed.
2. Connect the appropriate wire from the Motor Power cables to the M1, M2, M3, and PE terminals on the Gold DBWhistle.
3. Make sure not to bundle the wires.
4. The phase connection is arbitrary as Elmo Application Studio (EAS II) will establish the proper commutation automatically during setup. When tuning a number of drives, you can copy the setup file to the other drives and thus avoid tuning each drive separately. In this case the motor-phase order must be the same as on the first drive.
5. For high EMI environment, it is highly recommended to use a 4-wire shielded (not twisted) cable for the motor connection. The gauge is determined by the actual RMS current consumption of the motor.
6. Connect the cable shield to the closest ground connection at the motor end.
7. For better EMI performance, the shield should be connected to Earth Connection (heat sink mounting holes).



7.3. Main Power

This section describes the Main Power .

7.3.1. Main Power

The VDC isolated from the Mains DC power source is not included with the Gold DBWhistle.

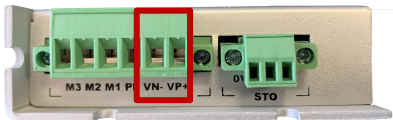
Pin	Function	Cable	Pin Positions
VP+	DC Pos. Power input	Power	
PR	Power output return	Power	
PE	Protective earth	Power	

Table 5 : Connector for Main Power

Connect the DC power cable to the VP+ and PR terminals on the main power connector.

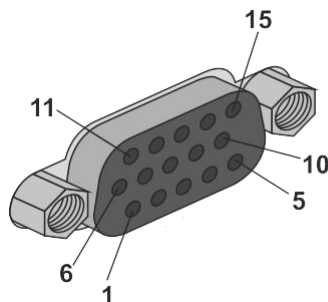
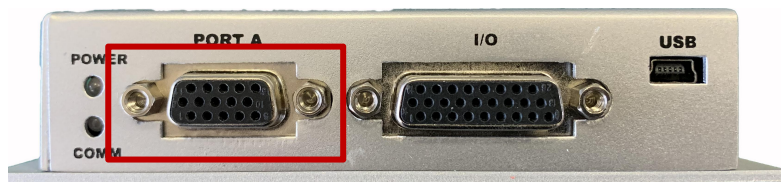
To connect the Gold DBWhistle to the DC power source:

1. The source of the VDC power supply must be isolated from the Mains.
2. Verify that the rectified VDC is indeed within the range of the drive.
3. Connect the VP+ and PR wires to the terminals on the servo-drive.
4. It is highly recommended to twist the two DC main power cables at intervals of 10 cm.
5. Connect the PE to the closest earth connection near the power supply.
6. Connect the PR to the closest earth connection near the power supply.
7. Before applying power, first verify the polarity of the connection.

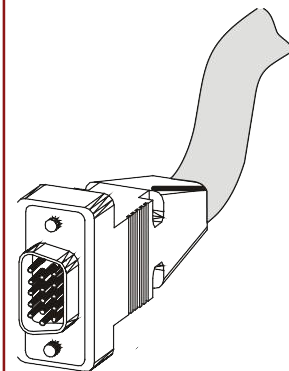


7.4. Feedback Connector

Pin (P1)	Incremental Encoder		Absolute Serial Encoder	
	Signal	Function	Signal	Function
13, 14, 15	+5V	Encoder +5V supply	+5V	Encoder +5V supply
11, 12	COMRET	Common return	COMRET	Common return
4	PortA_ENC_A+	Channel A+	ABS_CLK+	Abs encoder clock +
5	PortA_ENC_A-	Channel A-	ABS_CLK-	Abs encoder clock -
7	PortA_ENC_B+	Channel B+	ABS_DATA+	Abs encoder data +
8	PortA_ENC_B-	Channel B-	ABS_DATA-	Abs encoder data -
9	PortA_ENC_INDEX+	Index+	Reserved	Reserved
10	PortA_ENC_INDEX-	Index-	Reserved	Reserved
1	HA	Hall sensor A	HA	Hall sensor A
2	HB	Hall sensor B	HB	Hall sensor B
3	HC	Hall sensor C	HC	Hall sensor C



15-Pin D-Type Female Connector



15-Pin D-Type Male Connector

Table 6: Port A Pin Assignments



7.4.1. Port A

Refer to section 10.3 in the MAN-G-Board Level Modules Hardware Manual for further details of the Port A connections.

7.4.1.1. Incremental Encoder

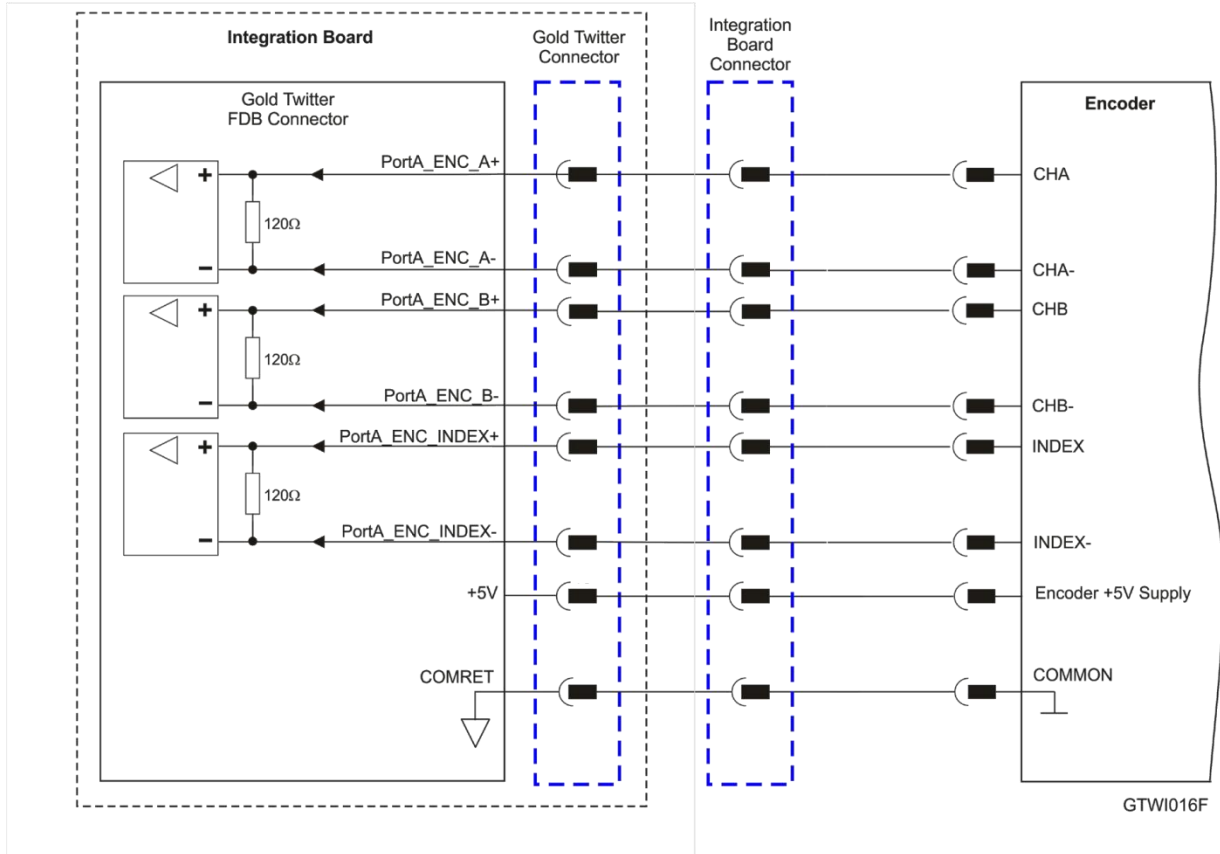


Figure 6: Port A Incremental Encoder Input – Recommended Connection Diagram



7.4.1.2. Absolute Serial Encoder

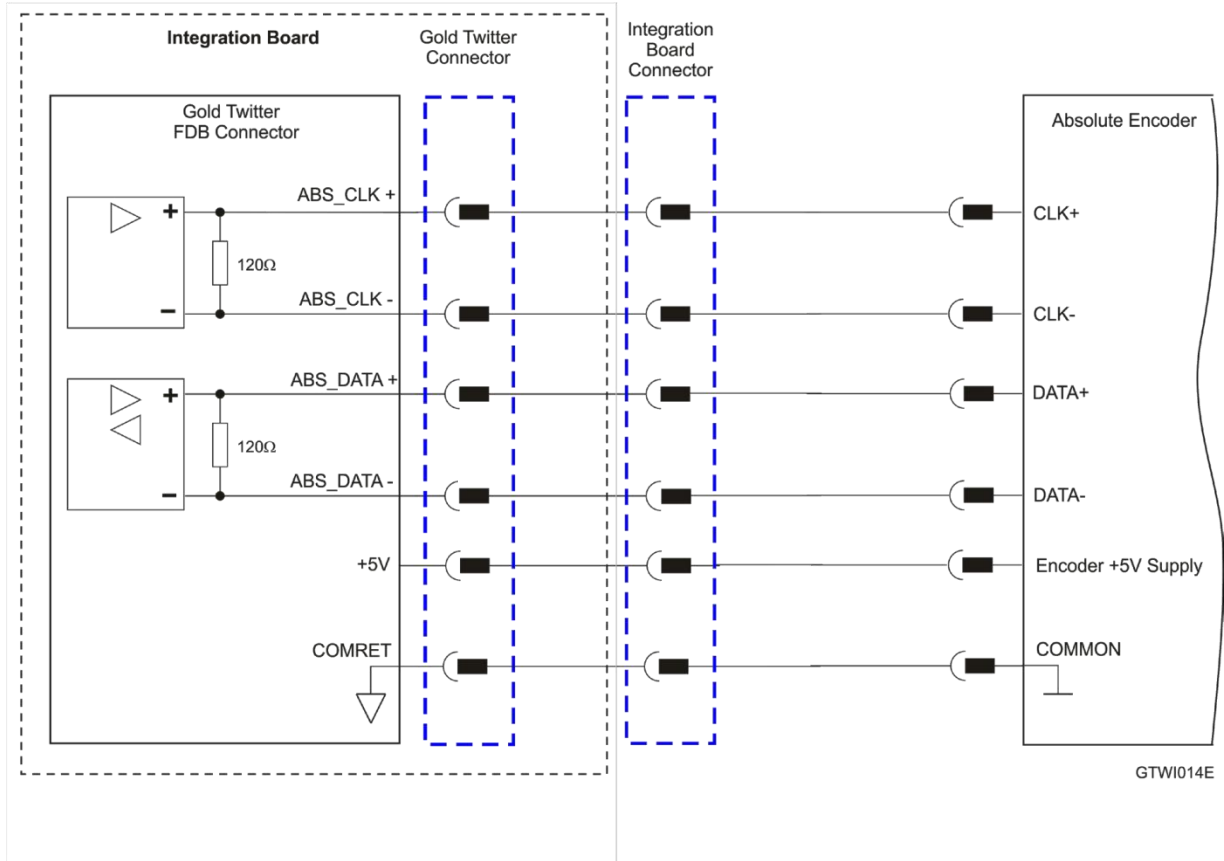


Figure 7: Absolute Serial Encoder – Recommended Connection Diagram for Sensors Supporting Data/Clock (e.g., Biss / SSI / EnDAT, etc.)

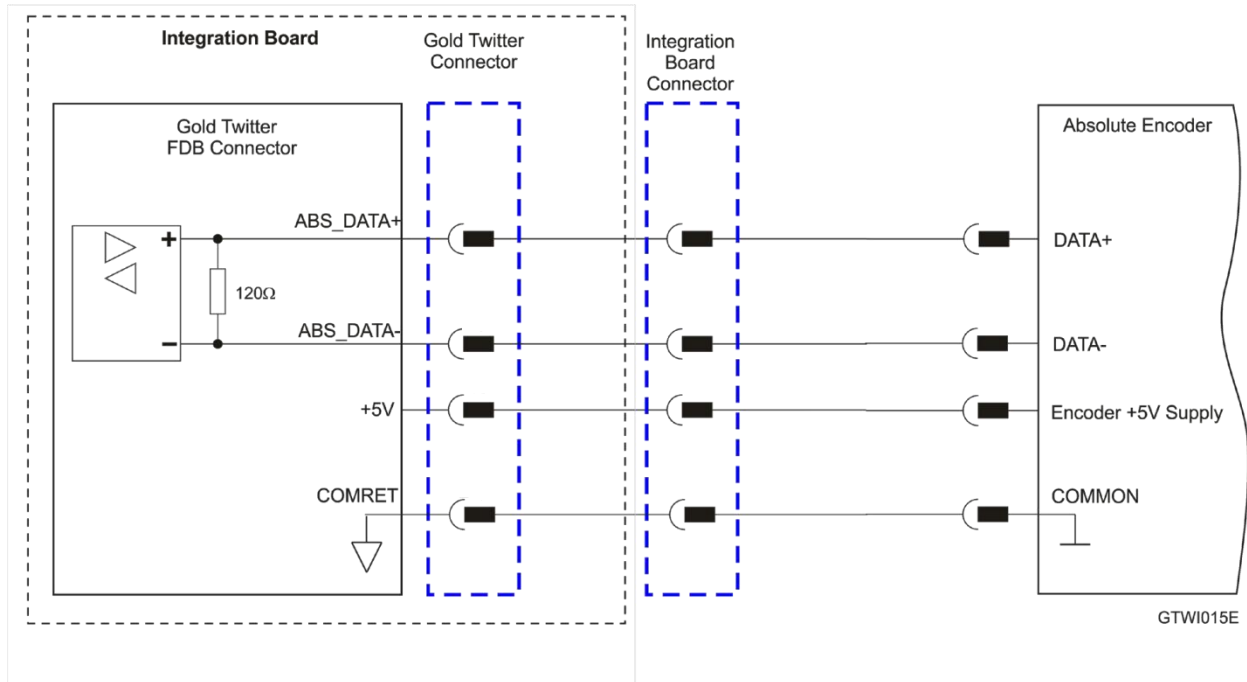


Figure 8: Absolute Serial Encoder – Recommended Connection Diagram for Sensors Supporting Data Line Only (NRZ types, e.g., Panasonic / Mitutoyo / etc.)



7.4.1.3. Hall Sensors

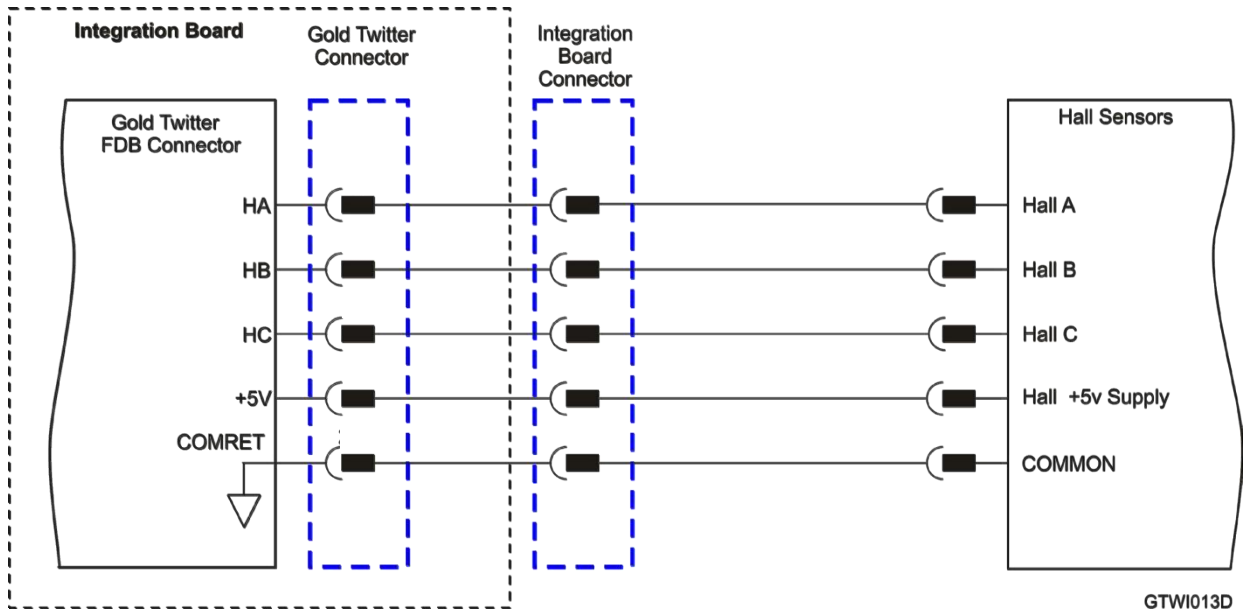


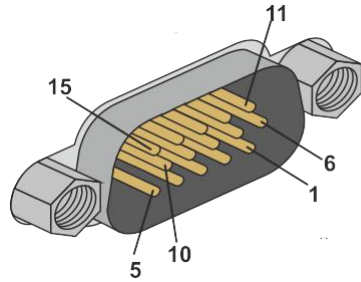
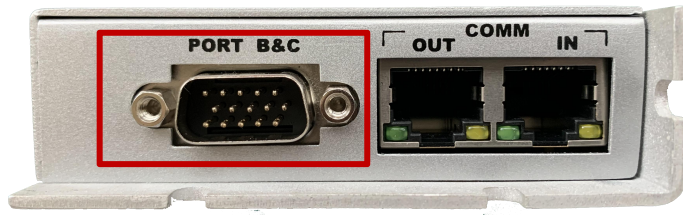
Figure 9: Hall Sensors Connection Diagram



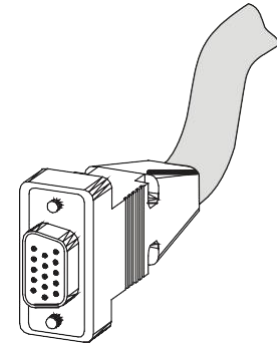
Port B & C		Incremental or Interpolated Analog Encoder		Resolver	
Pin	Signal	Function	Signal	Function	
7	+5V	Encoder +5V supply	NC		
8	COMRET	Common return	COMRET	Common return	
2	PortB_ENC_A+/SIN+	Incremental Encoder A+ / Sine+	SIN+	Sine+	
1	PortB_ENC_A-/SIN-	Channel A- / Sine-	SIN-	Sine-	
4	PortB_ENC_B+/COS+	Channel B+ / Cosine+	COS+	Cosine+	
3	PortB_ENC_B-/COS-	Channel B- / Cosine-	COS-	Cosine-	
6	PortB_ENC_INDEX+	Index+	RESOLVER_OUT+	Vref f=1/TS, 50 mA Max.	
5	PortB_ENC_INDEX-	Index -	RESOLVER_OUT-	Vref complement f= 1/TS, 50 mA Max.	
10	PortC_ENCO_A+	Buffered Channel A+/Pulse+/PWM+ output			
9	PortC_ENCO_A-	Buffered Channel A-/Pulse-/PWM- output			
14	PortC_ENCO_B+	Buffered Channel B+/Dir+ output			
15	PortC_ENCO_B-	Buffered Channel B-/Dir- output			
12	PortC_ENCO_Index+	Buffered Channel INDEX+ output			
13	PortC_ENCO_Index-	Buffered Channel INDEX- output			



Pin Positions



15-Pin D-Type Female Connector



15-Pin D-Type Male Connector

7. 4. 2. Port B & Port C

Refer to section 10.4 in the MAN-G-Board Level Modules Hardware Manual for further details of the Port B connections.

Refer to section 10.5 in the MAN-G-Board Level Modules Hardware Manual for further details of the Port C connections.



7.4.2.1. Incremental Encoder

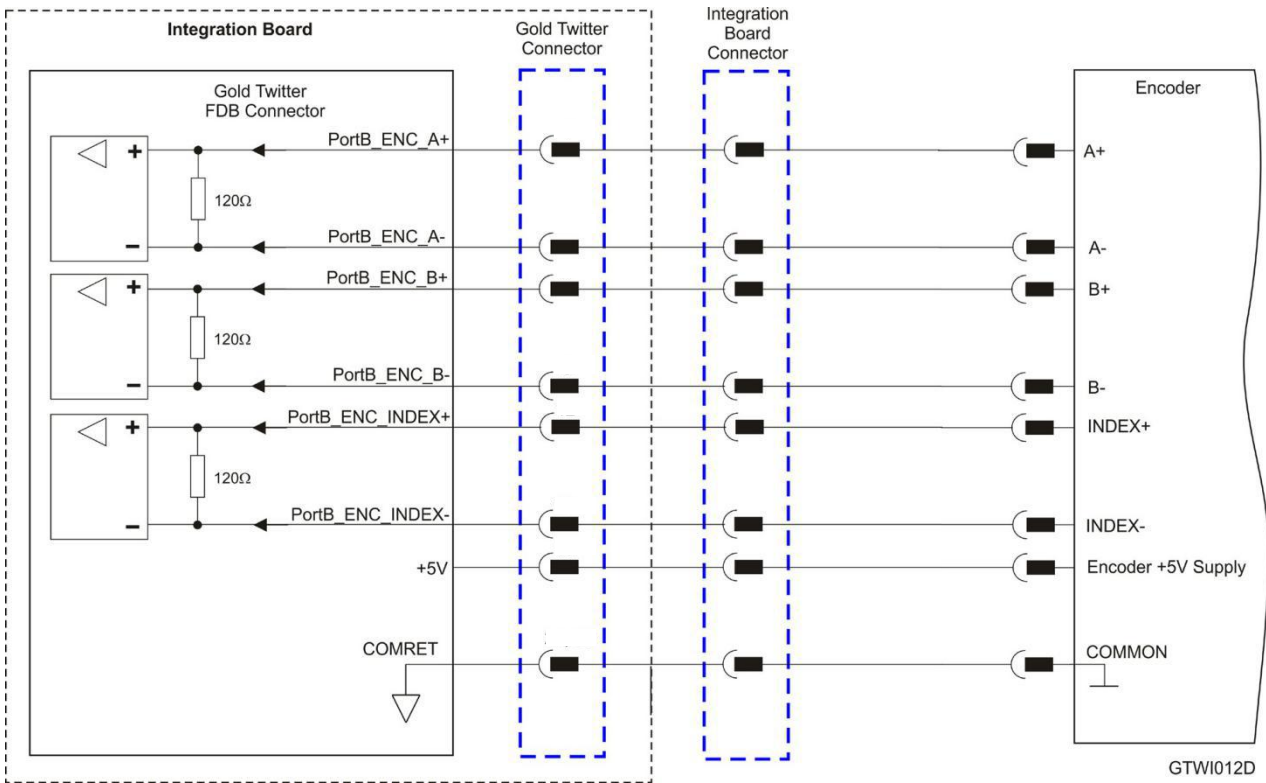


Figure 10: Port B Incremental Encoder Input – Recommended Connection Diagram



7.4.2.2. Interpolated Analog Encoder

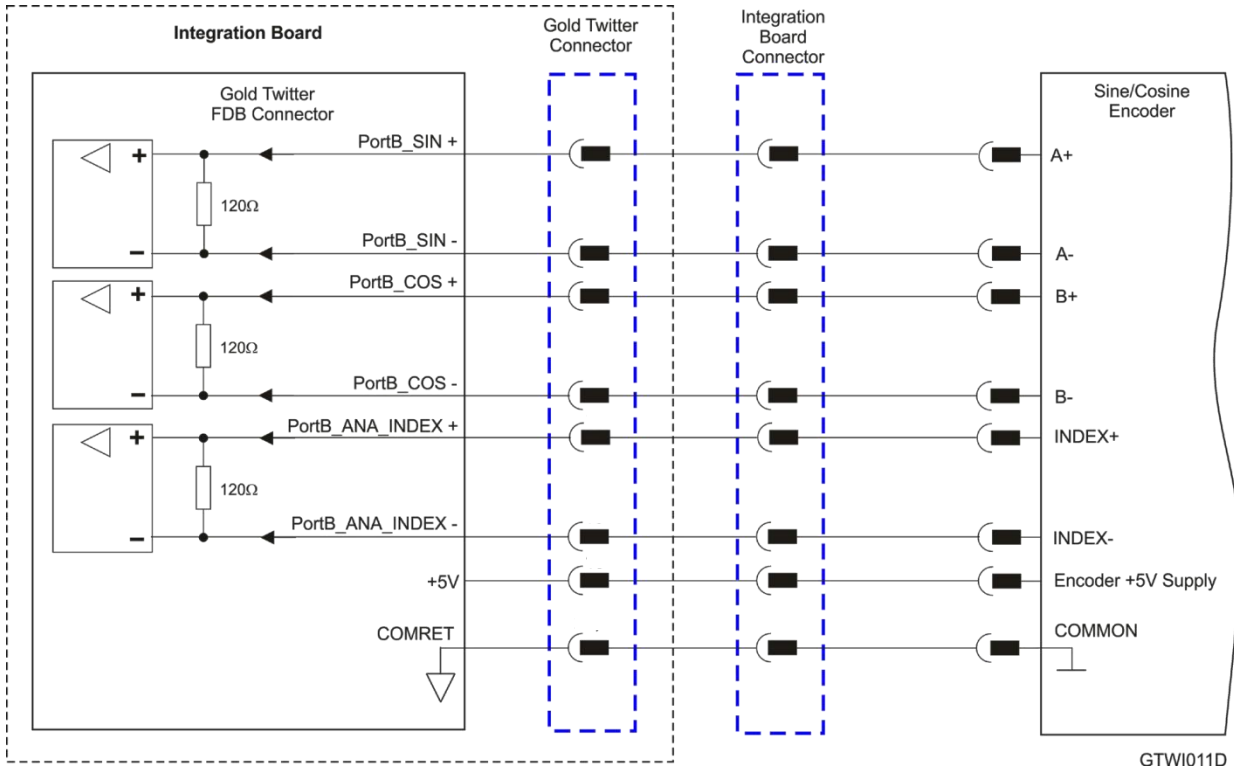


Figure 11: Port B - Interpolated Analog Encoder Connection Diagram



7.4.2.3. Resolver

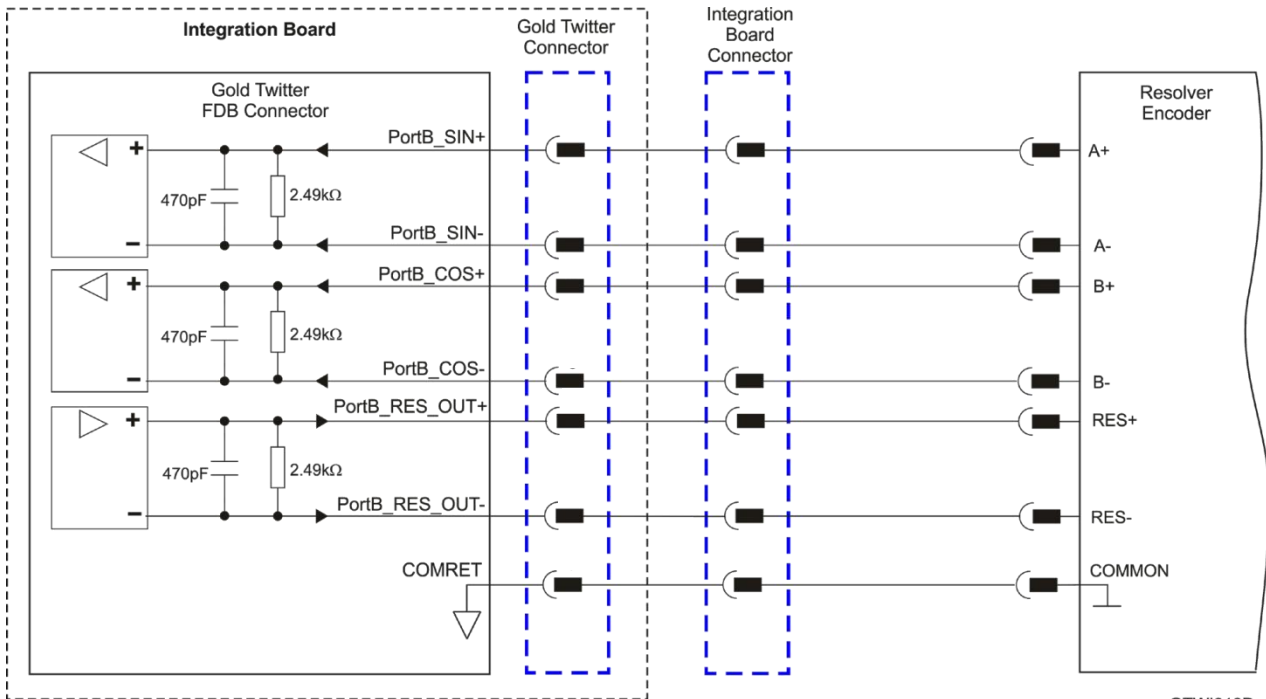


Figure 12: Port B – Resolver Connection Diagram

GTWI010D



7. 4. 3. Port C – Emulated Encoder Output

See Section 10.5 in the manual: MAN-G-Board Level Modules Hardware Manual for further details of Port C.

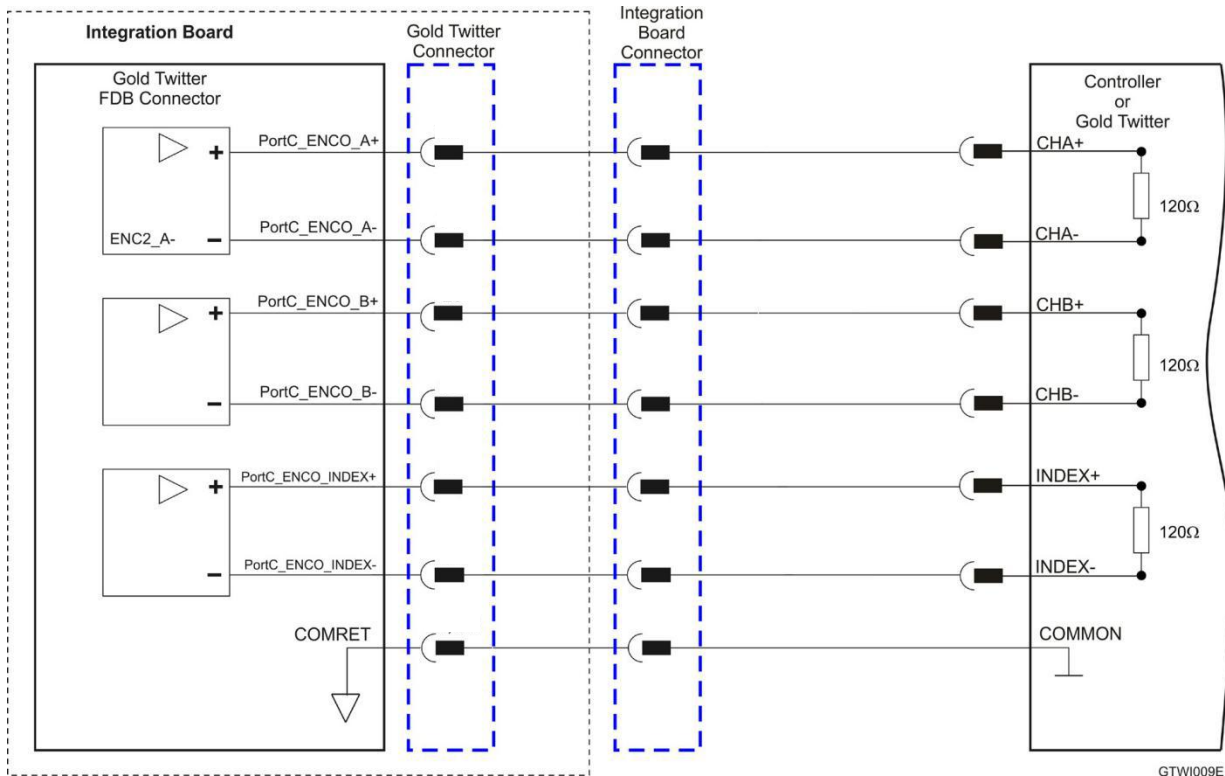


Figure 13: Emulated Encoder Differential Output – Recommended Connection Diagram



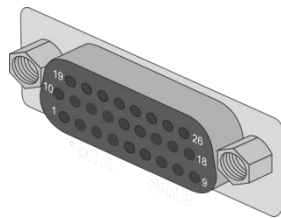
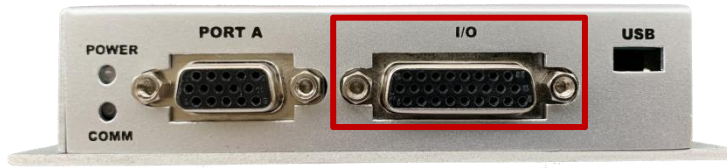
7.5. Digital Inputs , Digital Outputs, Analog Input and RS232

Refer to Chapter 11 in the in the MAN-G-Panel Mounted Drives Hardware manual for full details.

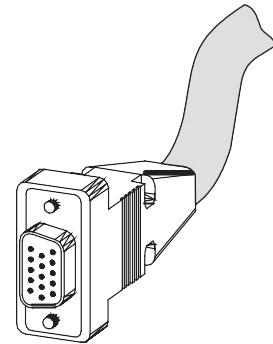
IO	Signal	Function
1		
2		
3		
4		
5	OUT2	Programmable output 2
6	OUTCOM2	Programmable output return 2
7	OUT1	Programmable output 1
8	OUTCOM1	Programmable output return 1
9		
10	VDD	Supply for out 1-4
11	VDD	Supply for out 1-4
12	IN6	High speed programmable input 6
13	IN5	High speed programmable input 5
14	IN4	High speed programmable input 4
15	IN3	High speed programmable input 3
16	IN2	High speed programmable input 2
17	IN1	High speed programmable input 1
18	INRET 1-6	Inputs 1 to 6 return
19	VDDRET	Supply return for out 1-2
20	VDDRET	Supply return for out 1-2
21	RS232-COM	
22	RS232_TX	
23	RS232_RX	
24	ANALRET	Analog Input Return
25	ANALOG1-	Analog input 1-
26	ANALOG1+	Analog input 1+



Pin Positions



26-Pin High Density D-Type Male Connector



26-Pin High Density D-Type Female Connector

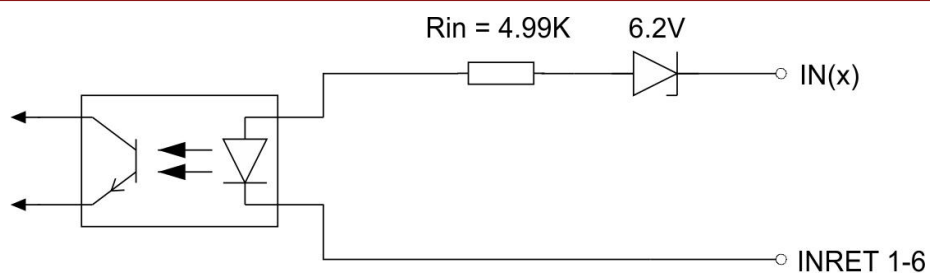


7. 5. 1. Digital Inputs

The following table describes the electrical specification of the inputs IN1 and IN6:

7.5.1.1. PNP Digital Input

Feature	Details
Standard	Isolated PLC source Conforming to IEC 61131-2
Input current	$I_{in} = (V_{in} - 7.4) / 4.99 \text{ Kohm}$ $I_{in} = 920 \text{ uA @ } V_{in} = 12 \text{ V}$ $I_{in} = 4.5 \text{ mA @ } V_{in} = 30 \text{ V}$
High-level input voltage	$12 \text{ V} < V_{in} < 30 \text{ V}$
Low-level input voltage	$0 \text{ V} < V_{in} < 7 \text{ V}$
Minimum pulse width	$> 250 \text{ } \mu\text{sec}$
Execution time (all inputs): the time from application of voltage on input until execution is complete	$0 < T < 250 \text{ } \mu\text{sec}$
High-speed inputs – 1–6 minimum pulse width, in high-speed mode	$T > 5 \text{ } \mu\text{sec}$ if the input functionality is set to latch/capture (index/strobe). <ul style="list-style-type: none">• Home mode is high-speed mode and can be used for fast capture and precise homing.• Highest speed is achieved when turning on optocouplers.
Capture with differential input Port A, Port B Index	$T > 0.1 \text{ } \mu\text{sec}$ if the differential input functionality is set to touch probe/capture (index/strobe).





The following are the connection diagram of Digital inputs:

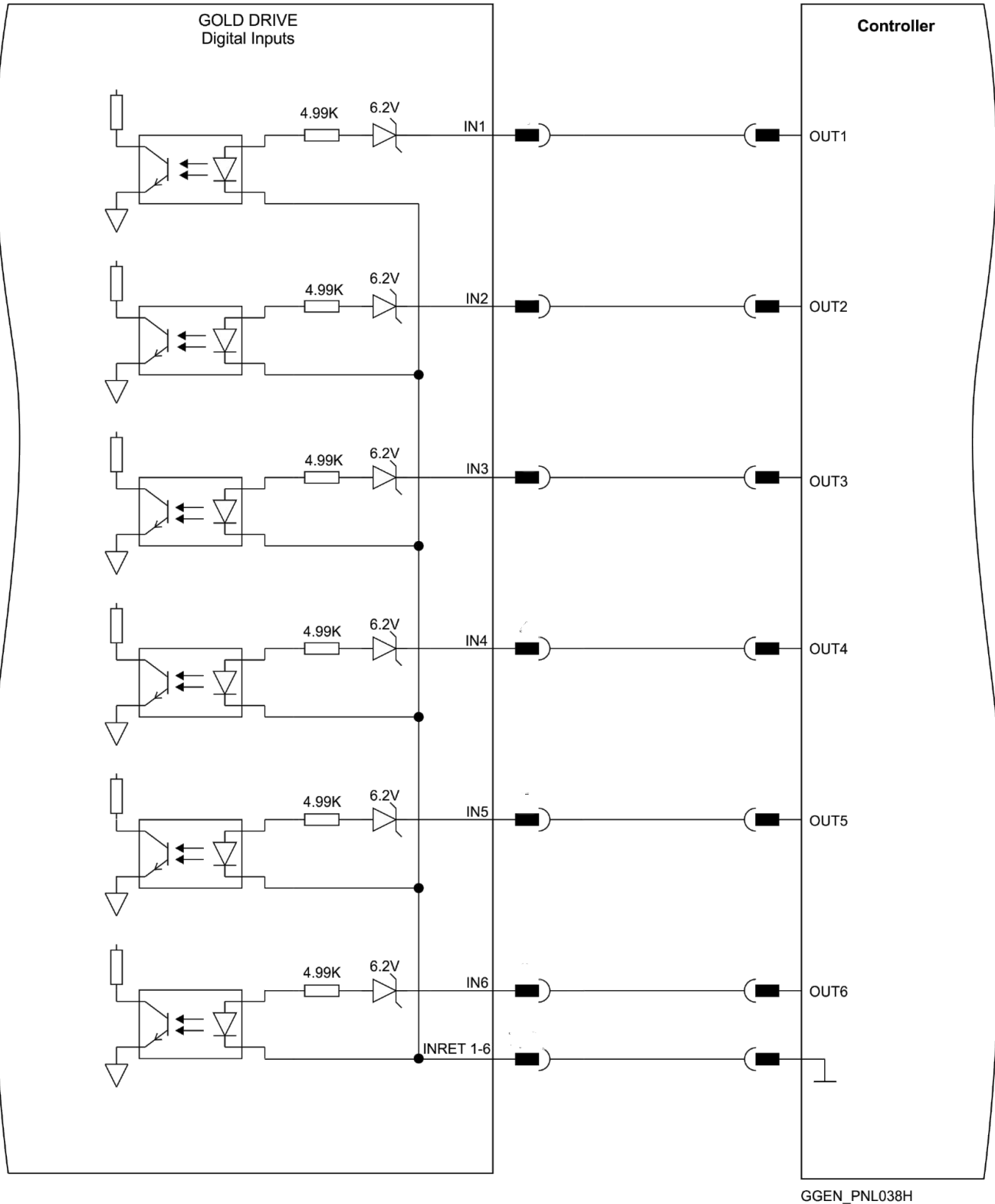


Figure 14: Digital Input Connection Diagram Example – PNP



7.5.1.2. NPN Digital Input

Feature	Details
Type of input	Isolated PLC Sink
Input current	$I_{in} = (V_{in} - 7.4) / 4.99K\Omega$ $I_{in} = 920 \mu A @ V_{in} = 12V$ $I_{in} = 4.5 mA @ V_{in} = 30V$
High-level input voltage	$12V < V_{in} < 30V$
Low-level input voltage	$0V < V_{in} < 7V$
Minimum pulse width	$> 250 \mu sec$
Execution time (all inputs): the time from application of voltage on input until execution is complete	$0 < T < 250 \mu sec$
High-speed inputs – 1–6 minimum pulse width, in high-speed mode	$T > 5 \mu sec$ if the input functionality is set to latch/capture (index/strobe). <ul style="list-style-type: none"> • Home mode is high-speed mode and can be used for fast capture and precise homing. • Highest speed is achieved when turning on optocouplers.
Capture with differential input Port A, Port B Index	$T > 0.1 \mu sec$ if the differential input functionality is set to touch probe/capture (index/strobe).

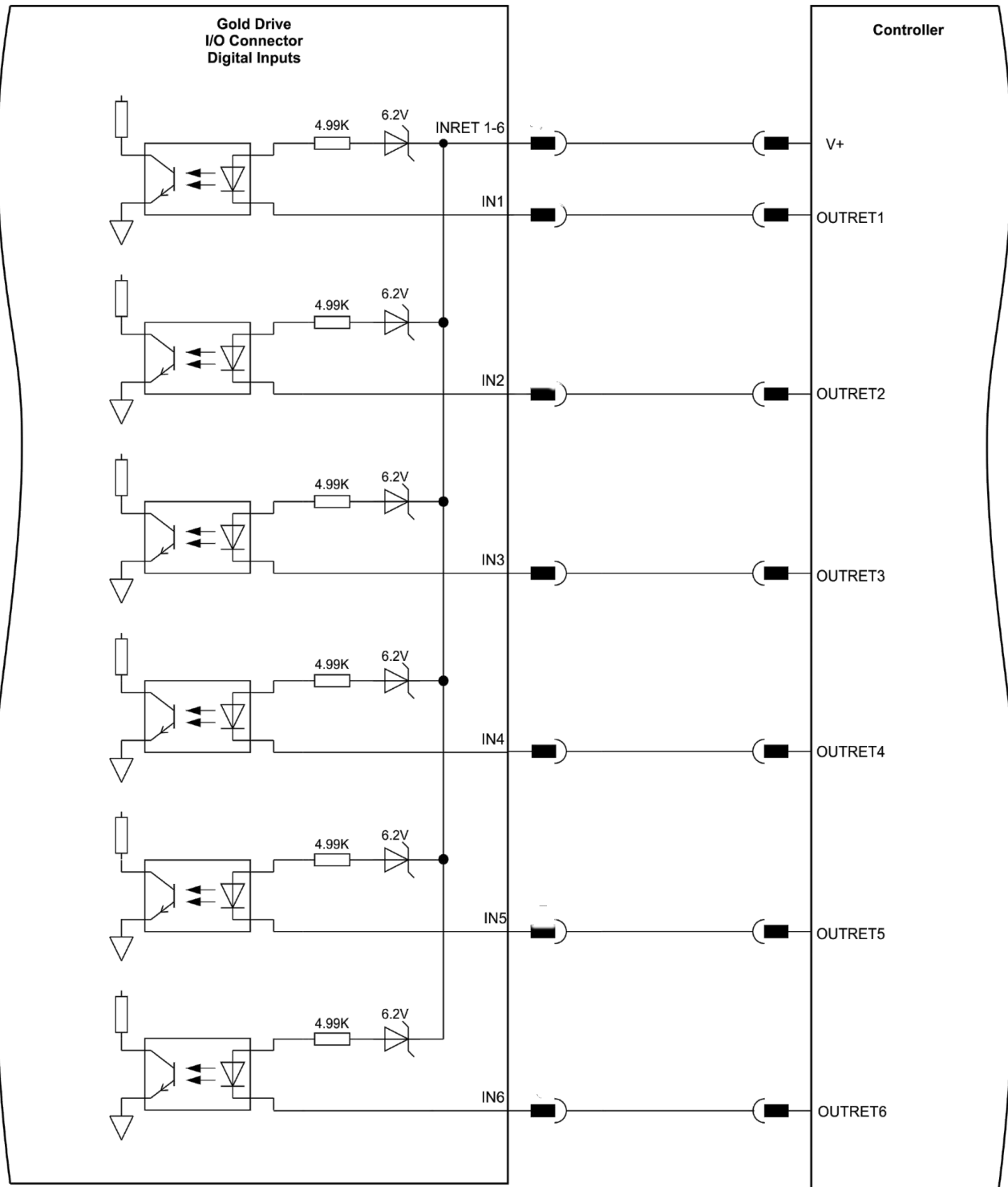
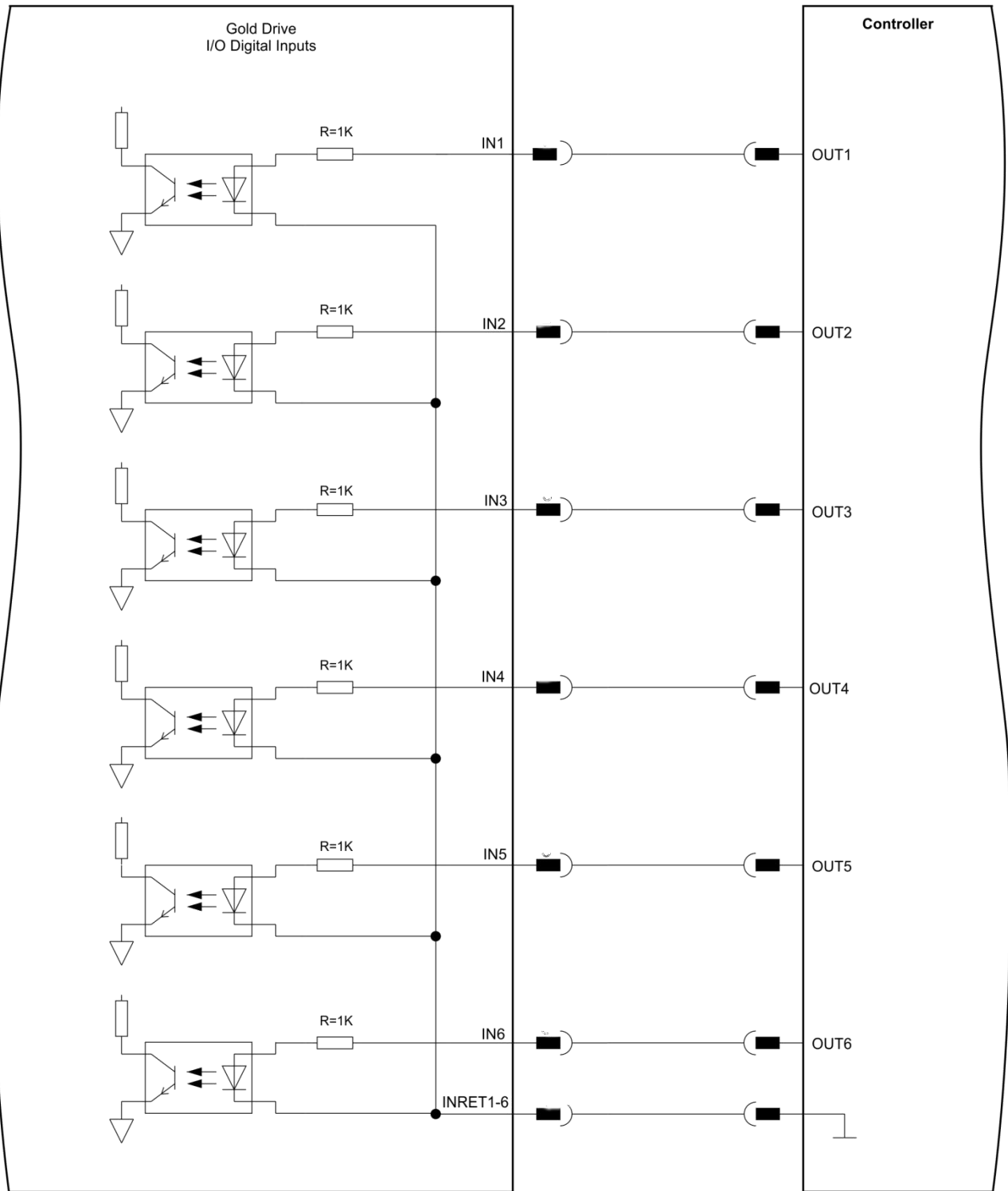


Figure 15: Digital Input Connection Diagram Example – NPN



7.5.1.3. Source 5V Logic Level Digital Input

Feature	Details
Type of input	Optically isolated
Input current for all inputs	$I_{in} = 3.8 \text{ mA} @ V_{in} = 5 \text{ V}$
High-level input voltage	$3.0 \text{ V} < V_{in} < 10 \text{ V}$, 5 V typical
Low-level input voltage	$0 \text{ V} < V_{in} < 0.8 \text{ V}$
Minimum pulse width	$> 250 \mu\text{sec}$
Execution time (all inputs): the time from application of voltage on input until execution is complete	$0 < T < 250 \mu\text{sec}$
High-speed inputs – 1–6 minimum pulse width, in high-speed mode	<p>$T > 5 \mu\text{sec}$ if the input functionality is set to latch/capture (index/strobe).</p> <p>Home mode is high-speed mode and can be used for fast capture and precise homing.</p> <p>Highest speed is achieved when turning on optocouplers.</p>



GGEN_MOLEX037J

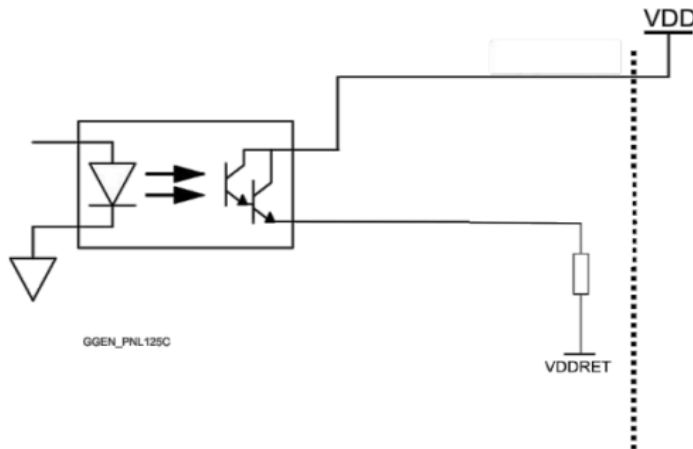
Figure 16: Digital Input Source 5V Logic Mode Connection Diagram



7. 5. 2. Digital Outputs

7.5.2.1. PNP Level Digital Output

Feature	Details
Type of output	Optically isolated PLC source
Supply output (VDD)	12V to 30V (typically 24V)
Max. output current $I_{out(max)} (V_{out} = High)$	$I_{out(max)} \leq 2A$
Collector Emitter saturation voltage	1V
T_{on} (Time from low to high) If $V_{dd} = 24V$	< 15usec
T_{off} (Time from high to Low)	< 250usec
R_L	The external R_L must be selected to limit output current to no more than 2 A. $R_L = \frac{VDD-1}{I_{out(max)}}$
Executable time	$0 < T < 250 \mu sec$



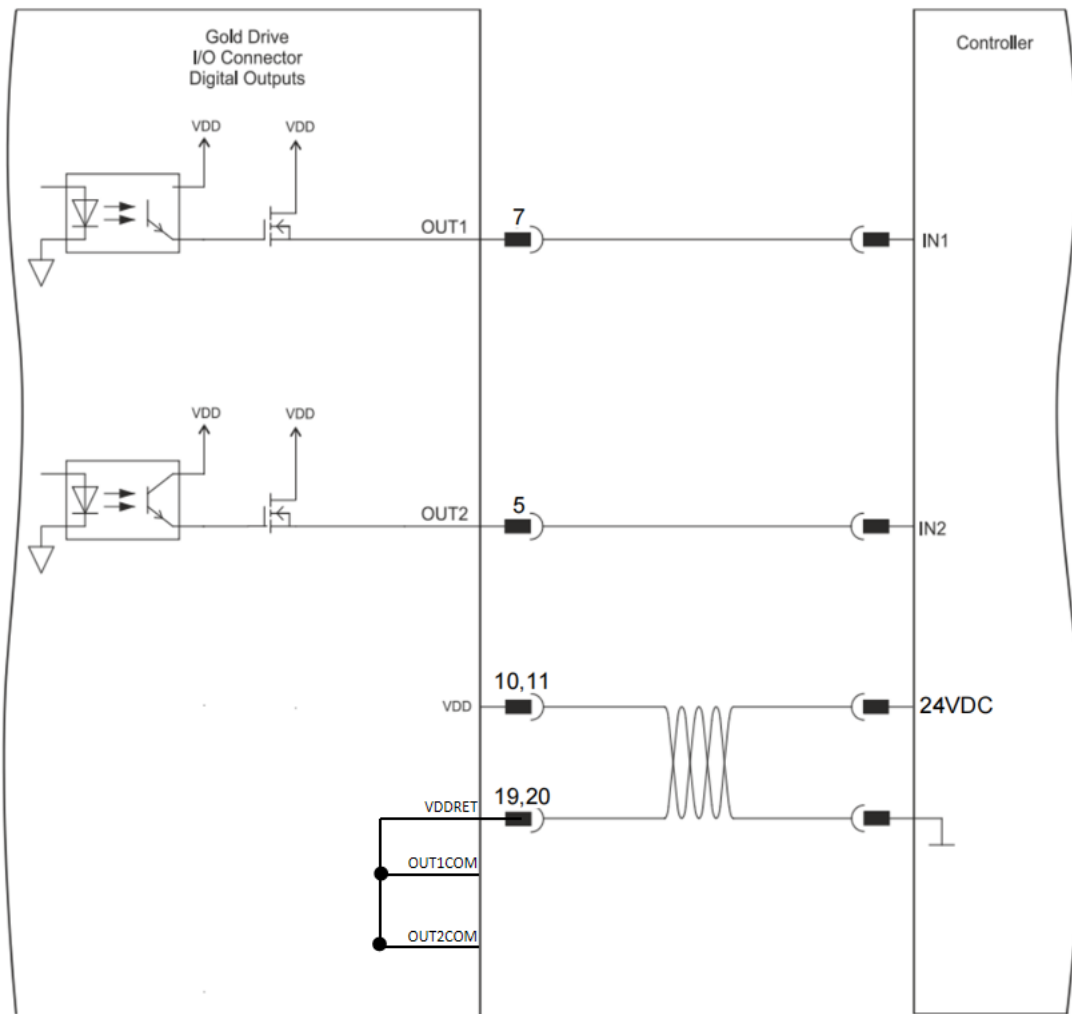


Figure 17: Digital Output Connection Diagram Example – PNP



7.5.2.2. NPN Digital Output

Feature	Details
Type of output	Optically isolated PLC Sink
Supply output (VDD)	12V to 30V (Typically 24V)
Max. output current $I_{out(max)} (V_{out} = Low)$	$I_{out(max)} \leq 2 A$
Collector Emitter saturation voltage	1V
T_{on} (Time from low to high) If $V_{dd} = 24V$	< 15usec
T_{off} (Time from high to Low)	< 300usec
R_L	The external R_L must be selected to limit output current to no more than 2 A. $R_L = \frac{VDD-1}{I_{out(max)}}$
Executable time	$0 < T < 250 \mu sec$

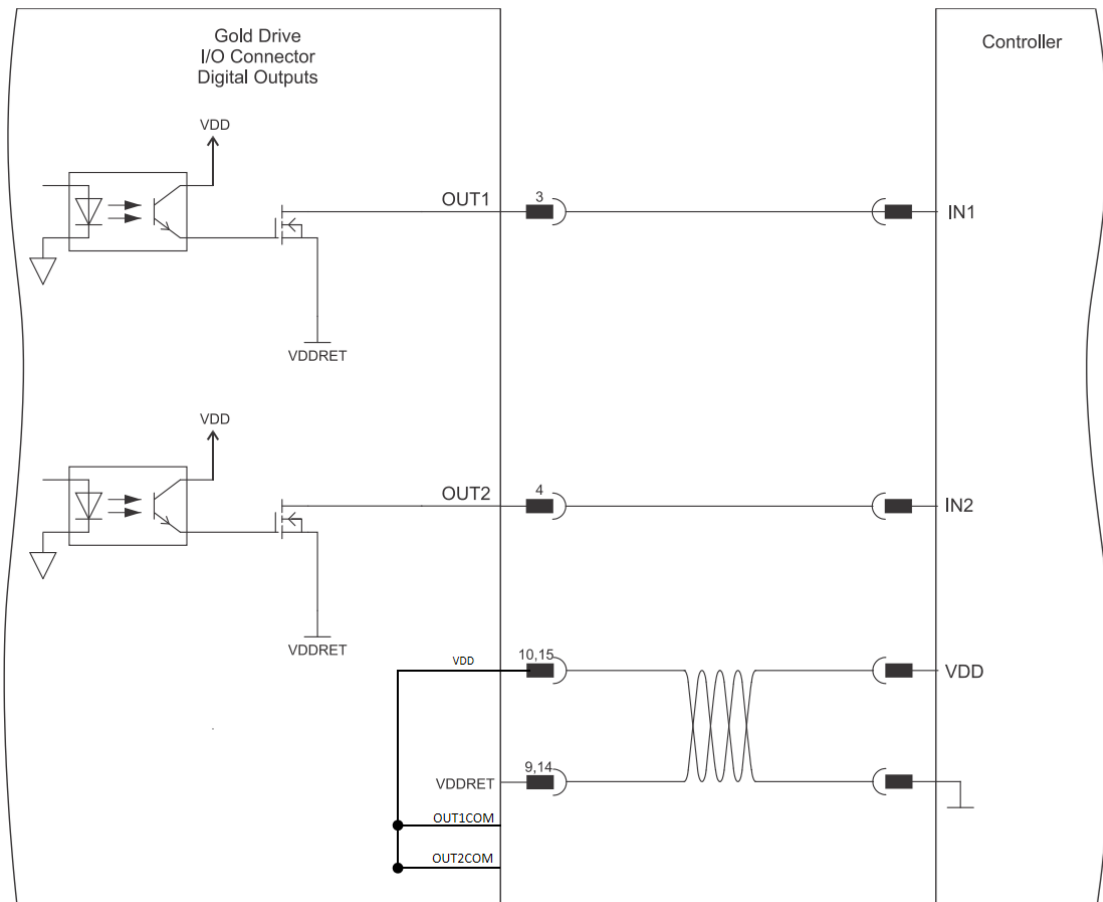


Figure 18: Digital Output Connection Diagram Example – NPN



7.5.2.3. Digital Outputs Source 5V Logic Mode

Feature	Details
Type of output	Optically isolated 5V Logic source
Supply output (VDD)	< 30 V (Typically 5 V)
Max. output current $I_{out} (max)$ ($V_{out} = High$)	$I_{out} (max) \leq 30 \text{ mA}$
Collector Emitter saturation voltage	1V
T_{on} (Time from low to high) If $V_{dd} = 5V$	< 10usec
T_{off} (Time from high to Low)	< 100usec
R_L	The external R_L must be selected to limit output current to no more than 30 mA. $R_L = \frac{VDD-1}{I_{out} (max)}$
Executable time	$0 < T < 250 \mu\text{sec}$

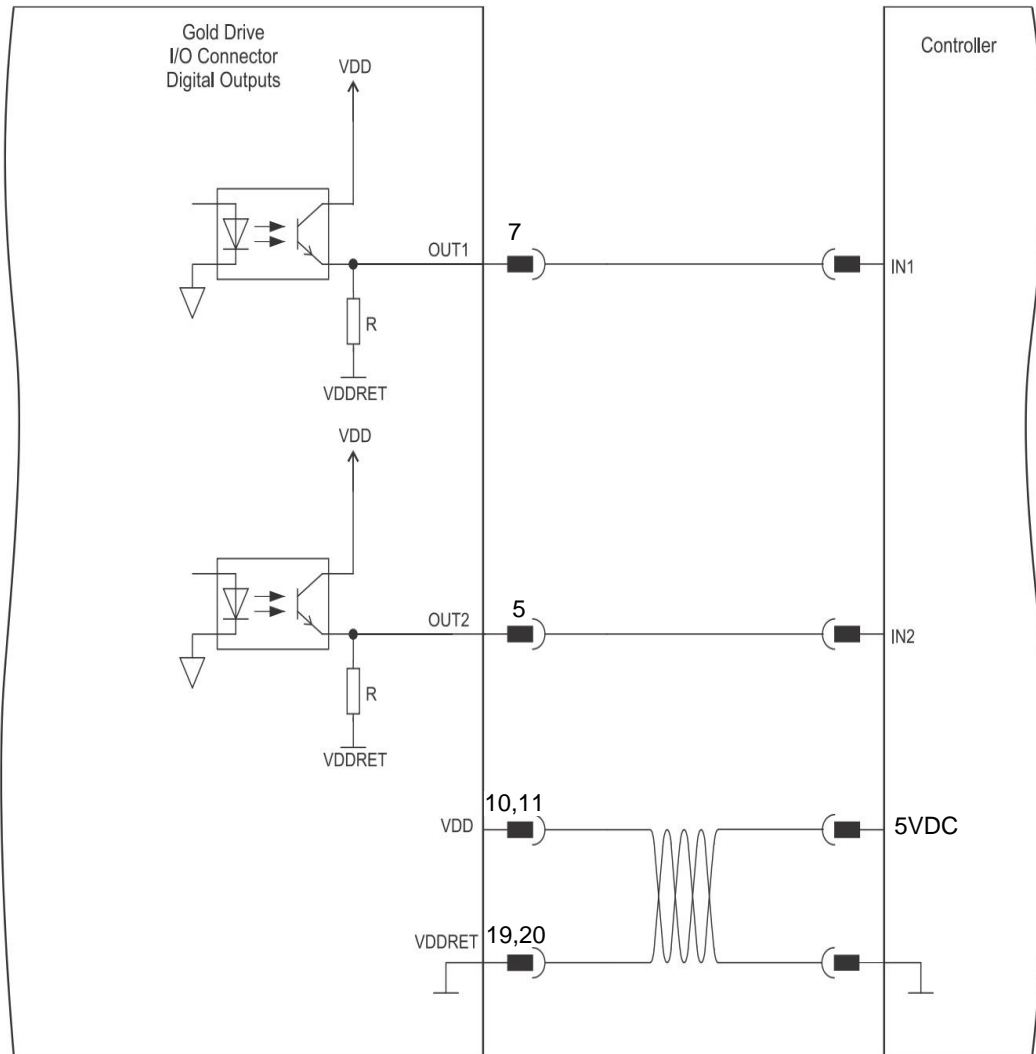


Figure 19: Digital Output Connection Diagram Example – Source 5V Logic Option



7. 5. 3. Analog Input

For full details on Analog Inputs, see section 11.3 in the MAN-G-Board Level Modules Hardware manual.

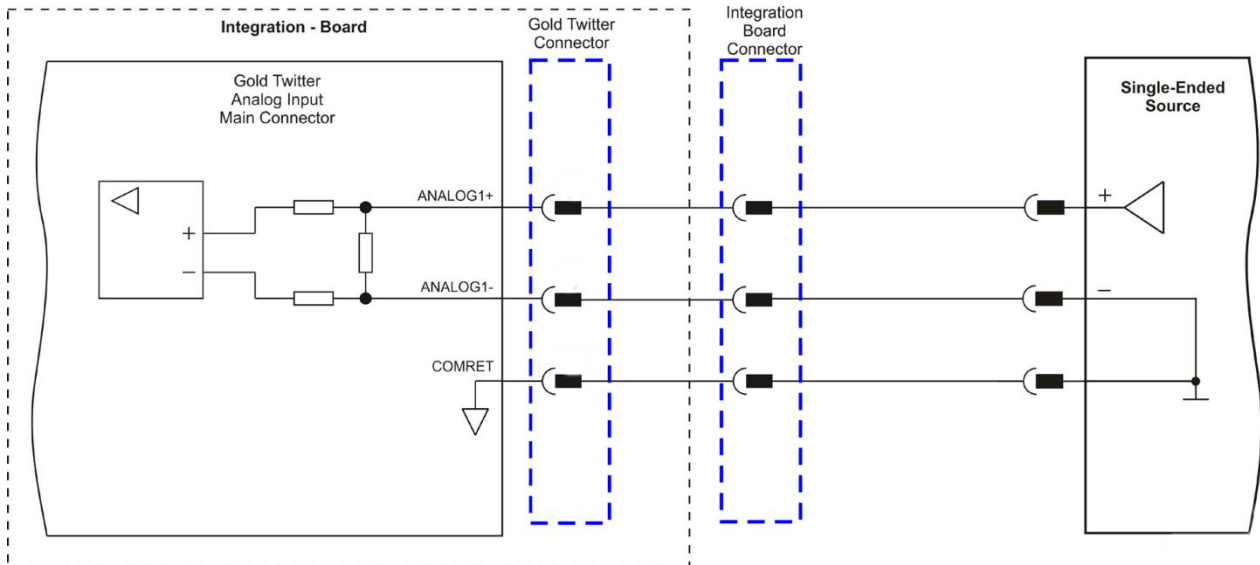


Figure 15: Analog Input



7. 5. 4. RS232

There are two types of RS232: Standard RS232 and RS232 TTL Level.

Figure 42 describes the Standard RS232 connection diagram.

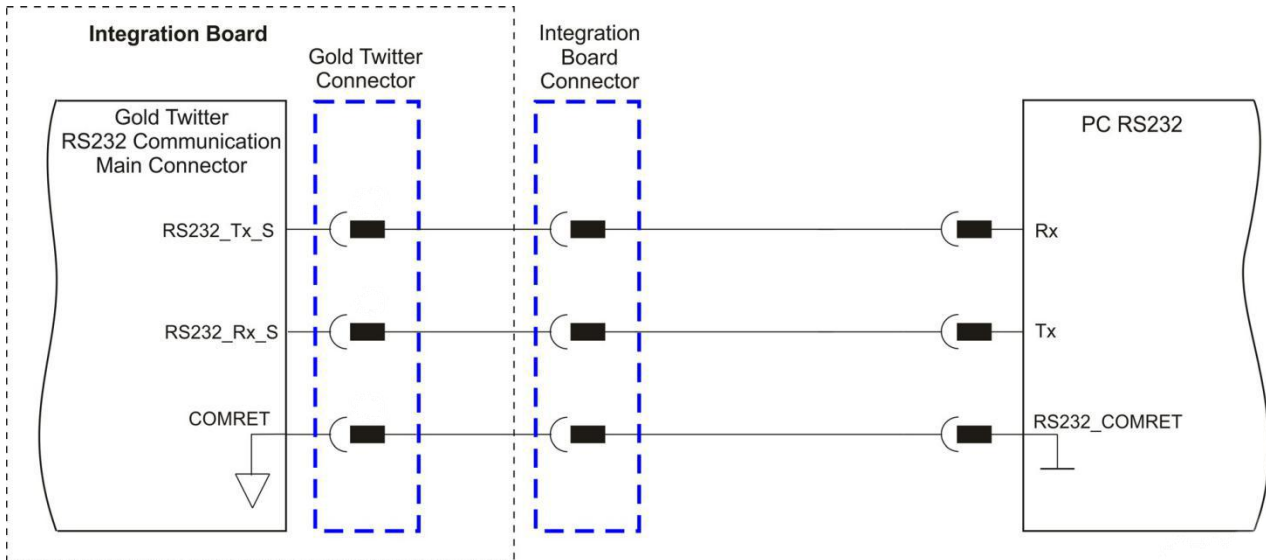


Figure 16: RS232 Connection Diagram

For full details on RS232 TTL Level communication, see section 12.5.1 in the MAN-G-Board Level Modules Hardware manual



7.6. EtherCAT Communications Version

Fieldbus communications are industrial network protocols for real-time distributed control that allows connection of servo drives. The Gold Oboe supports the following EtherCAT fieldbus type industrial network protocol:

7.6.1. EtherCAT IN/Ethernet Pinouts

Refer to section 12.2 in the MAN-G-Panel Mounted Drives Hardware manual for more details.

Pin on EtherCAT IN	Signal	Function
1	EtherCAT_IN_TX+/Ethernet_TX+	EtherCAT in transmit+/Ethernet transmit +
2	EtherCAT_IN_TX-/Ethernet_TX-	EtherCAT in transmit-/Ethernet transmit -
3	EtherCAT_IN_RX+/Ethernet_RX+	EtherCAT in receive+/Ethernet receive +
4/5	N/A	
6	EtherCAT_IN_RX-/Ethernet_RX-	EtherCAT in receive-/Ethernet receive -
7/8	N/A	

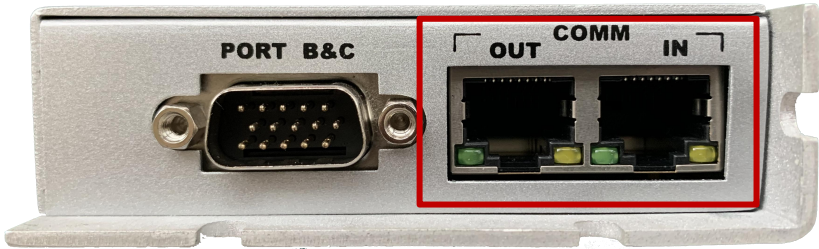
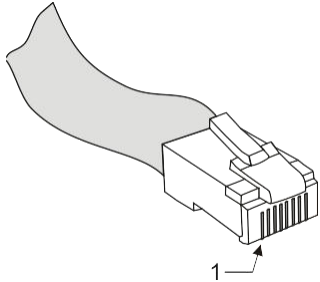
Pin Positions	
 <p>EtherCAT IN RJ-45 Connector</p>	 <p>Standard CAT5e Ethernet Cable</p>

Table 7: EtherCAT In/Ethernet Connector Pin Assignments



7. 6. 2. EtherCAT OUT Pinouts

See Section 12.2 in the MAN-G-Panel Mounted Drives Hardware manual for the electrical diagram.

Pin on EtherCAT OUT	Signal	Function
1	EtherCAT_OUT_TX+	EtherCAT out transmit +
2	EtherCAT_OUT_TX-	EtherCAT out transmit -
3	EtherCAT_OUT_RX+	EtherCAT out receive +
4/5	N/A	
6	EtherCAT_OUT_RX-	EtherCAT out receive -
7/8	N/A	

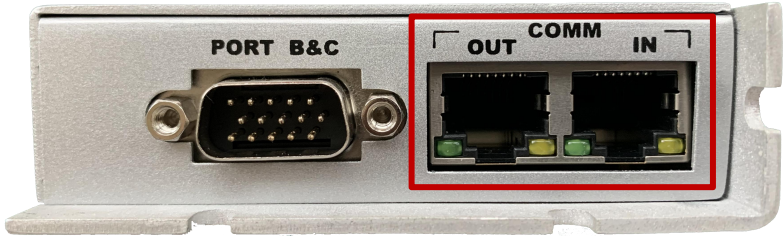
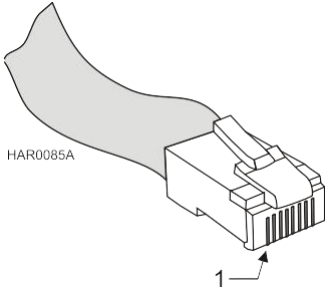
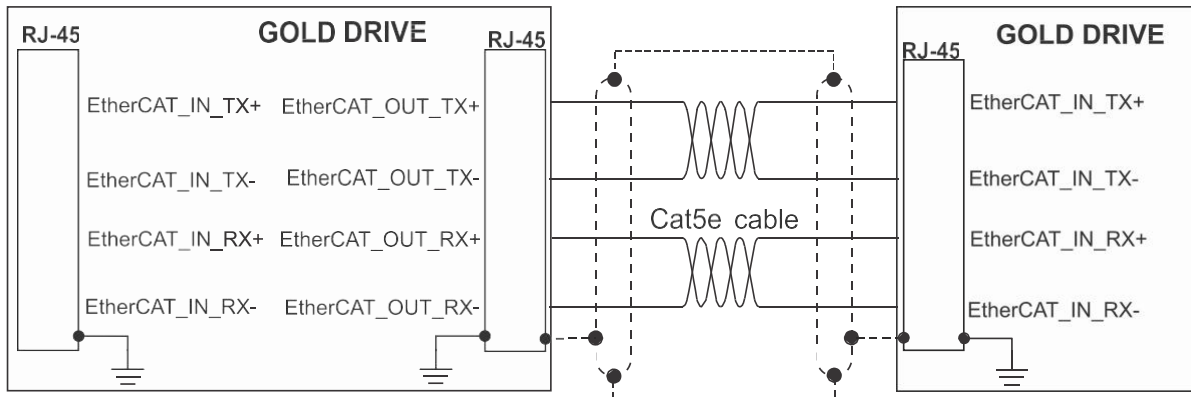
Pin Positions	
 <p>EtherCAT OUT RJ-45 Connector</p>	 <p>Standard CAT5e Ethernet Cable</p>

Table 8: EtherCAT Out Connector Pin Assignments



7. 6. 3. EtherCAT Wiring

Figure 35 describes the wiring diagram for the EtherCAT connections.



GGEN_DTYPE077C

Figure 17: EtherCAT RJ-45 Connections

7. 6. 4. EtherCAT Link Indicators

The Gold DBWhistle can serve as an EtherCAT slave device. For this purpose it has two RJ-45 connectors, which are designated as EtherCAT In and EtherCAT Out. Each of these RJ-45 connectors has two status LEDs, which are shown in Figure 36.

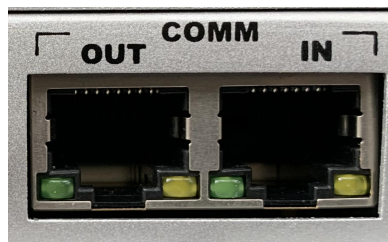


Figure 36: Ethernet Connector LEDs

The green LED is the link/activity indicator. It shows the state of the applicable physical link and the activity on that link. The amber LED is the speed indicator. It shows the speed of the connection on the Ethernet line. Refer to the section 12.2.2 in the document; MAN-G-Panel Mounted Drives Hardware manual.



7. 6. 5. EtherCAT Status Indicator



The EtherCAT status indicator is a red/green dual LED. It combines run indication (when it is green) and error indication (when it is red) of the EtherCAT device.

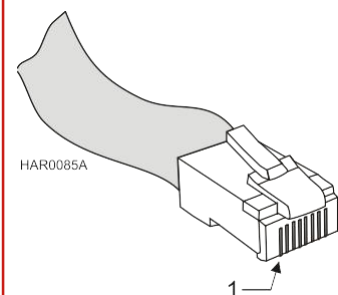
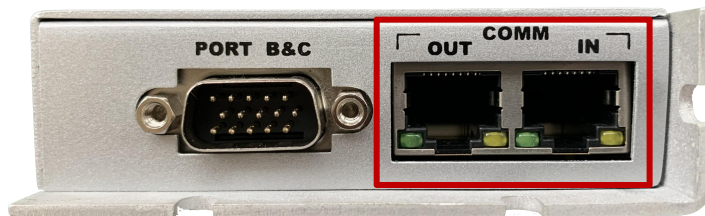
7.7. CAN Communications Version

Fieldbus communications are industrial network protocols for real-time distributed control that allows connection of servo drives. The Gold DBWhistle supports the following CAN fieldbus type industrial network protocol.

See Section 12.4 in the MAN-G-Panel Mounted Drives Hardware manual for the electrical diagram.

Pin on CAN	Signal	Function
1	CAN_H	CAN_H bus line (dominant high)
2	CAN_L	CAN_L bus line (dominant low)
3	CAN_RET	CAN Return
4, 5	N/A	—
6	CAN_SHLD	Shield, connected to the RJ plug cover
7	CAN_RET	CAN Return
8	N/A	—

Pin Positions



Standard CAT5e Ethernet Cable

Table 9: CAN In/Out Connector Pin Assignments



7. 7. 1. CAN Wiring

Figure 37 describes the CAN wiring diagram below.

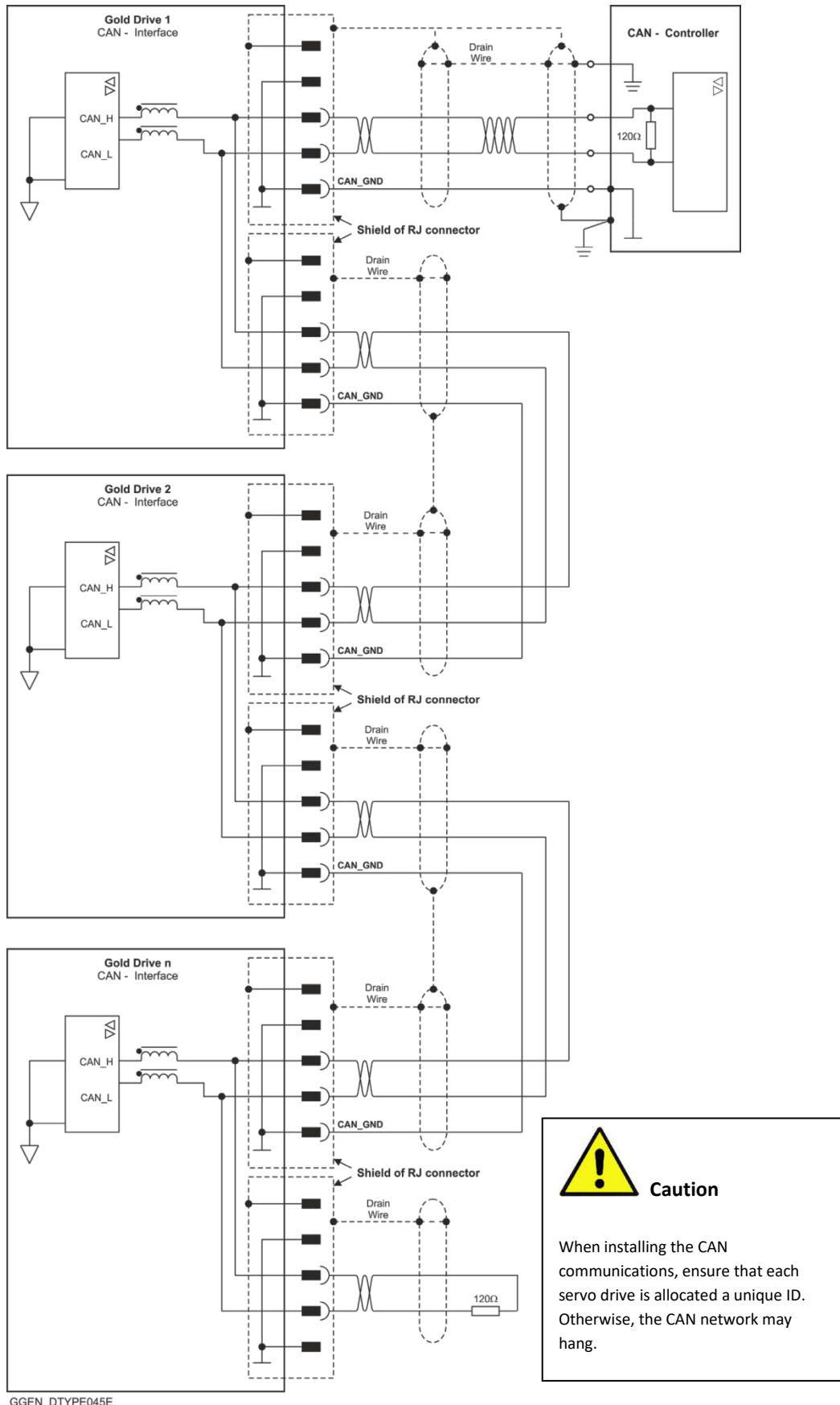


Figure 18: Gold Oboe Connection Diagram – CAN



7. 7. 2. USB 2.0 Communication (for EtherCAT model only)

For full details on USB communication, see section 12.1 in the MAN-G-Board Level Modules Hardware manual.

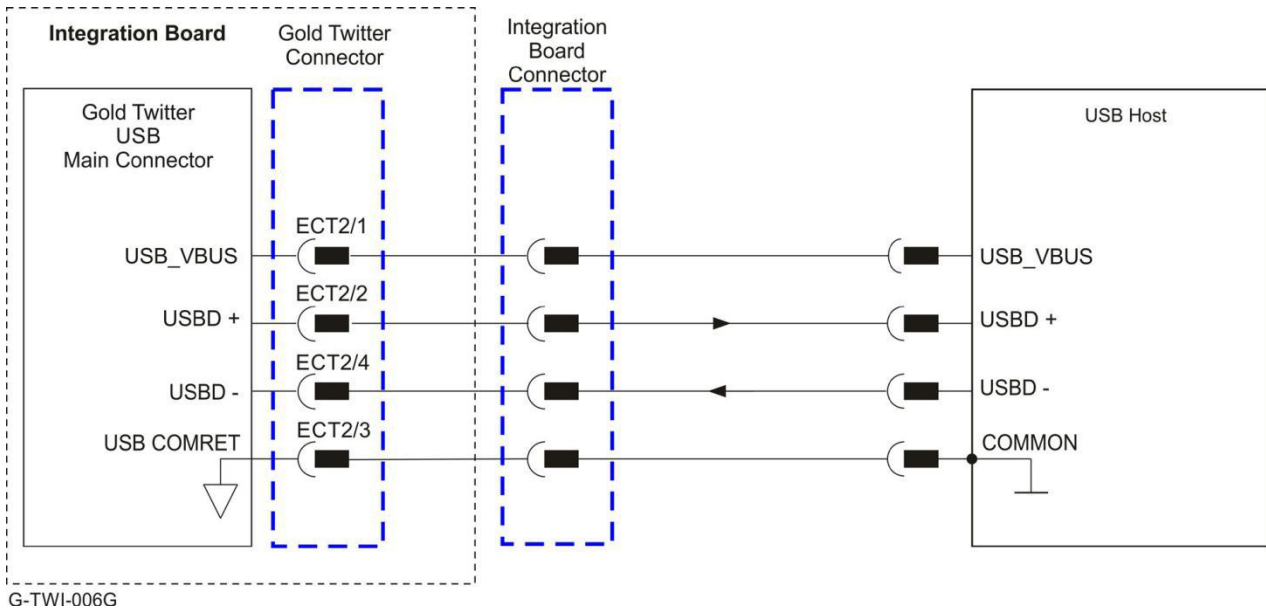


Figure 19: USB Network Diagram

For short distances between the drive and control, 0.5 to 1.0 m wires can be used and shielding is not required. For longer distances than 1.0 m and/or high EMI environment, shielded and twisted wires should be used. Drain wires should be connected to Elmo COMRET.



Chapter8: **Powering Up**

After the Gold DBWhistle is connected to its device, it is ready to be powered up.



.. Caution:

Before applying power, ensure that the DC supply is within the specified range and that the proper plus-minus connections are in order.

8.2. Initializing the System

After the Gold DBWhistle has been connected and mounted, the system must be set up and initialized. This is accomplished using the *EASII*, Elmo's Windows-based software application. Install the application and then perform setup and initialization according to the directions in the *EASII User Manual*.

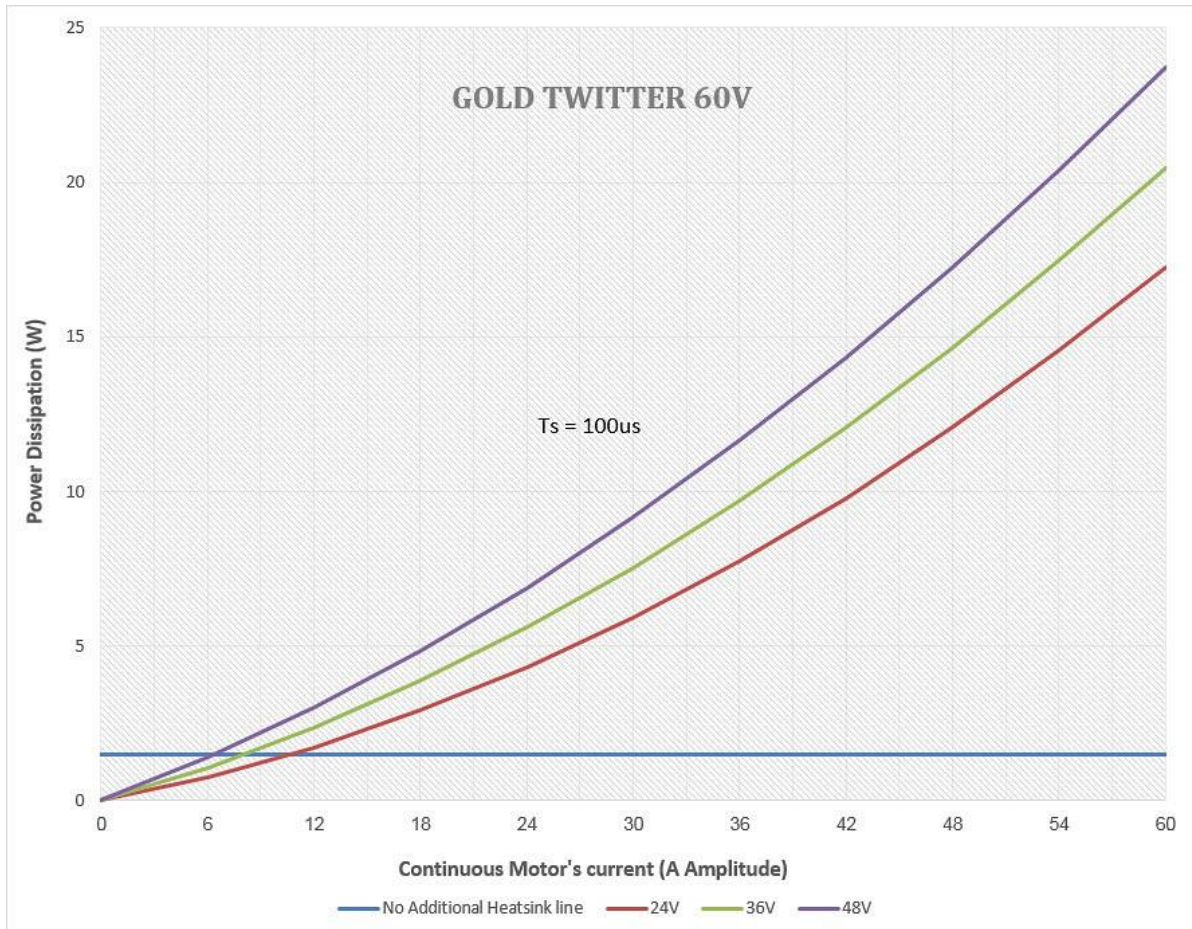


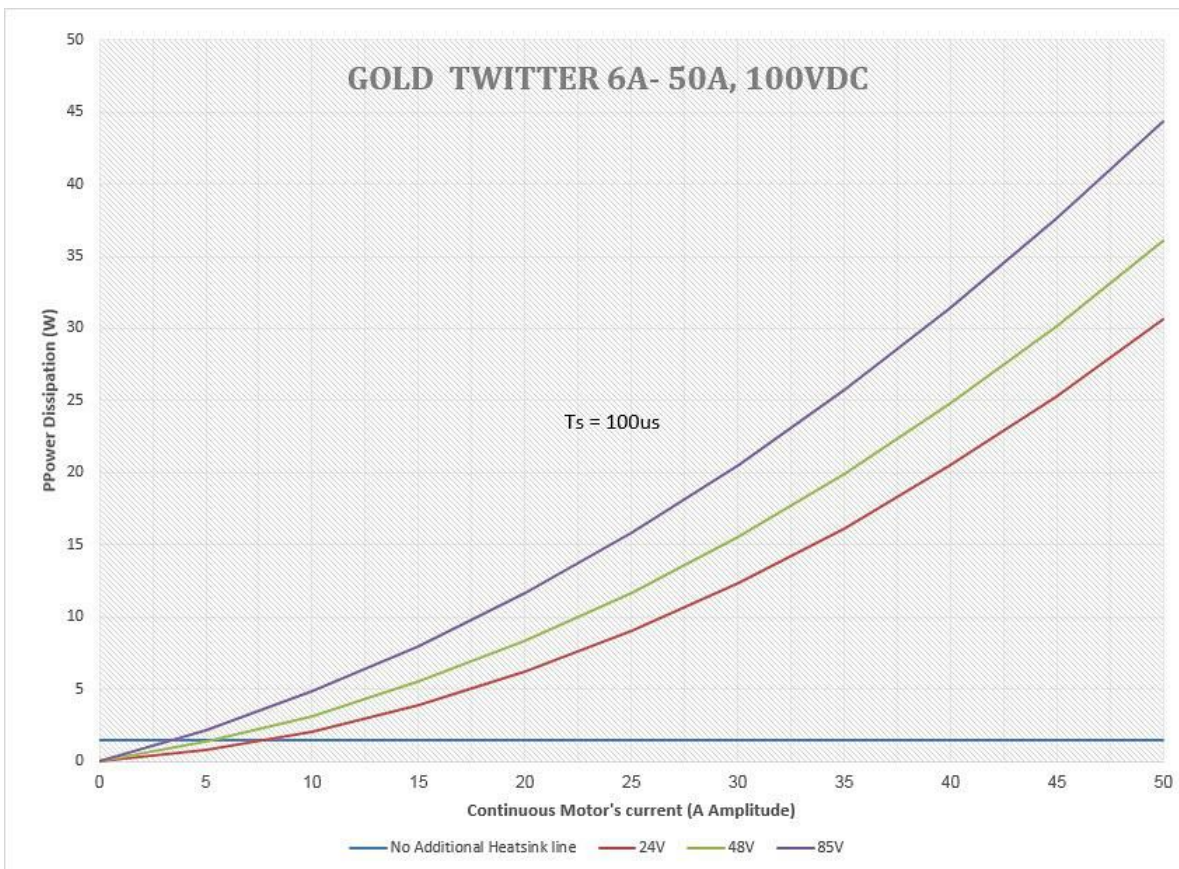
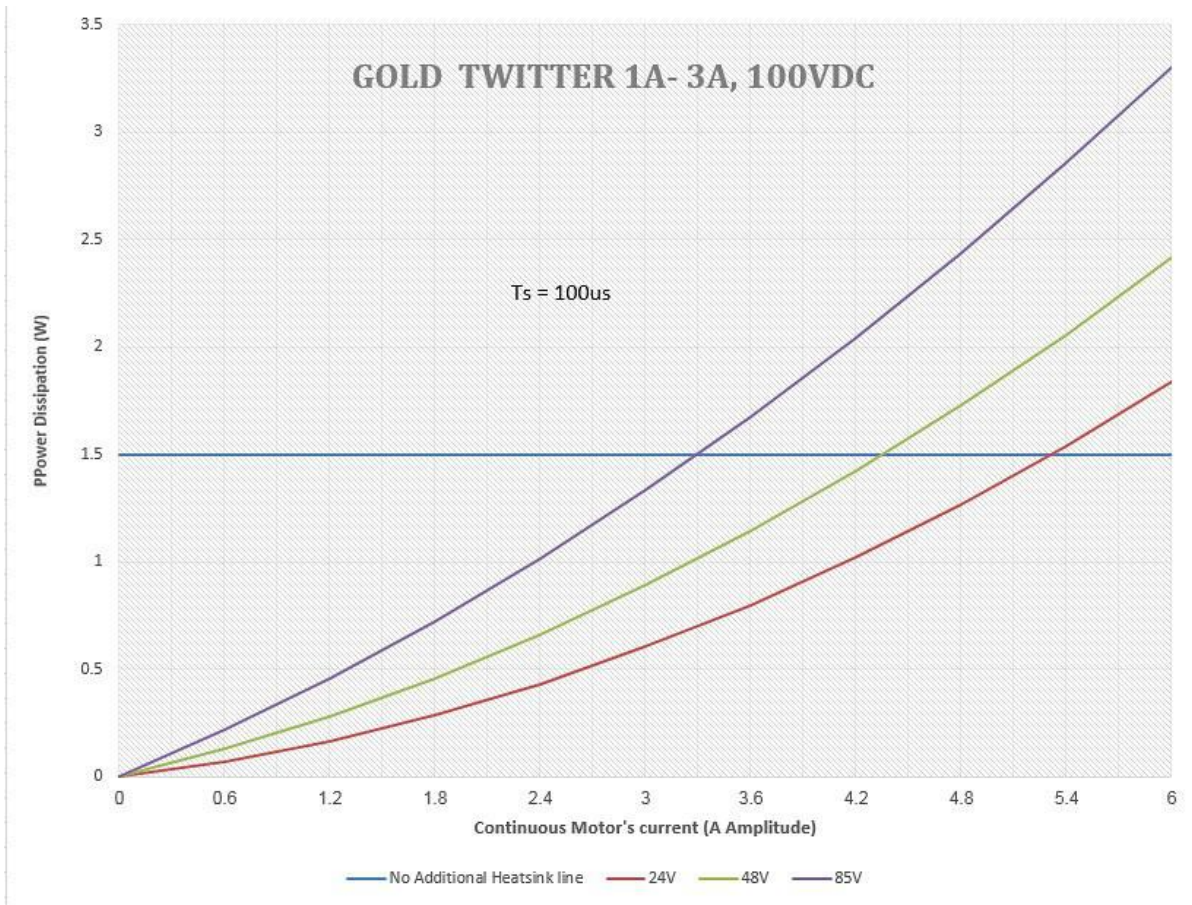
8.3. Heat Dissipation

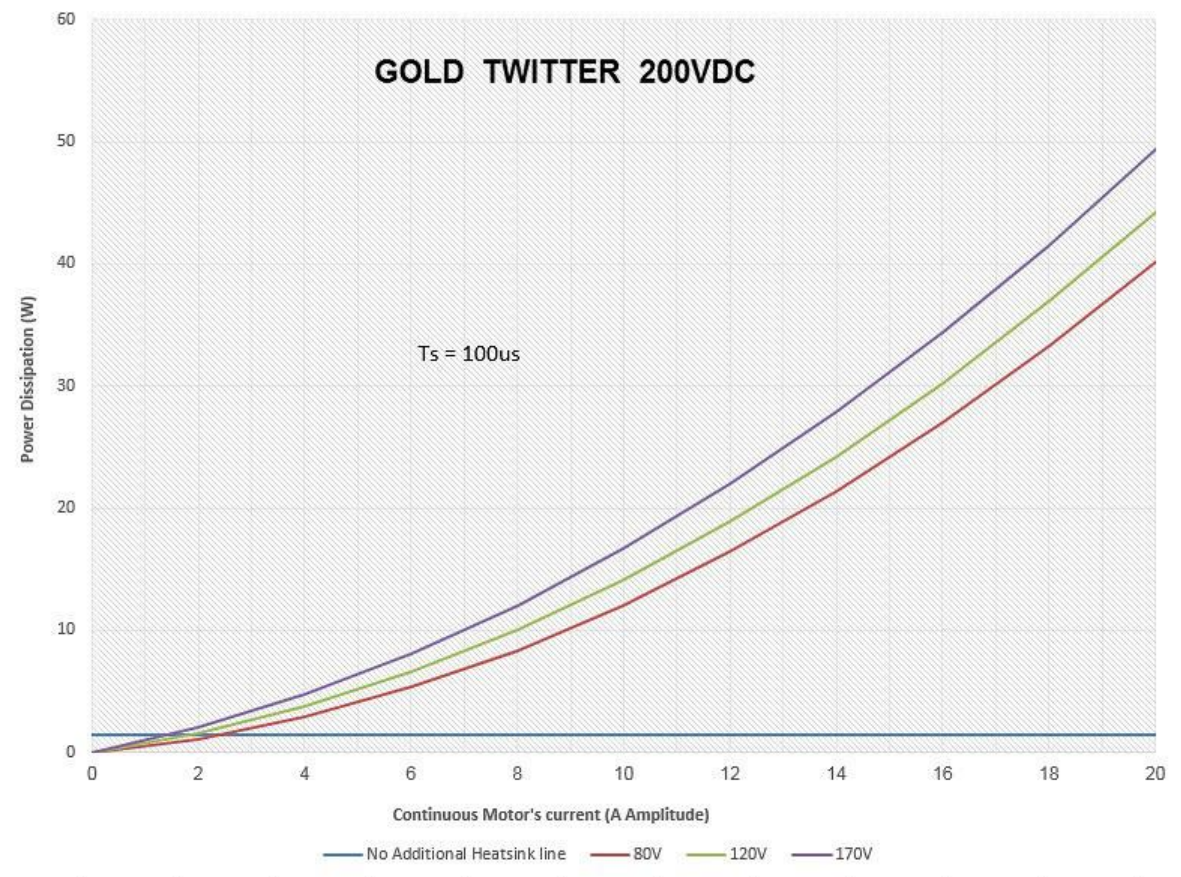
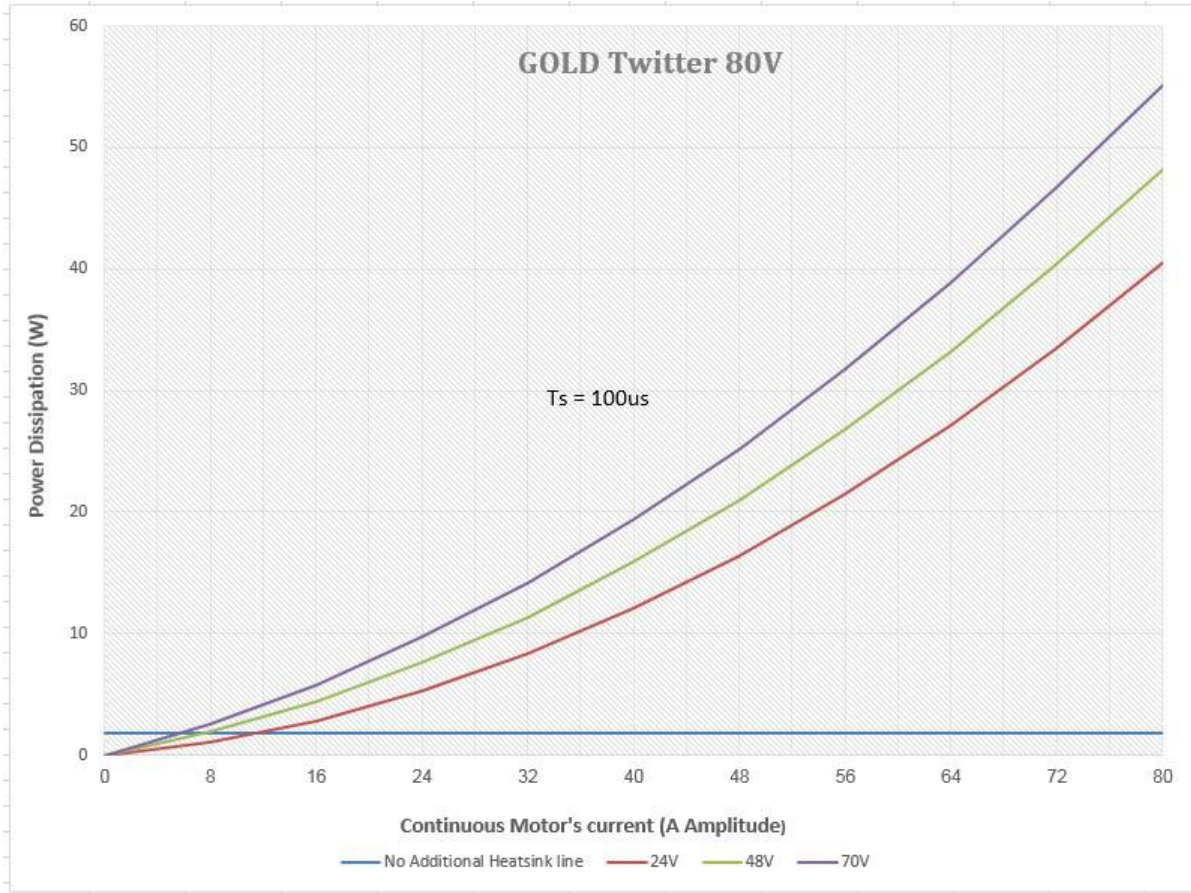
The best way to dissipate heat from the Gold DBWhistle is to mount it so that its heat-sink is attached to the machine chassis. If mounted with its heat-sink suspended, then for best results mount the servo drive faced upwards and leave approximately 10 mm of space between the Gold DBWhistle's heat-sink and any other assembly.

8.3.1. Heat Dissipation Data

Heat Dissipation is shown graphically below. **It should be noted in the graphs below that the Flat Heat Sink and Fins Heat Sink can dissipate up to 5.5W and 7.0W respectively:**









8.4. How to Use the Charts

The charts above are based upon the theoretical worst-case scenario. The actual test results display a 20% -30% lower power dissipation.

The above charts indicate the net power conversion losses and exclude the control losses.

To determine if your application heat dissipation requires a heat sink:

1、 Determine the power dissipation according to the "continuous current" and the DC bus voltage curve.

If the DC bus is not one of the three curves above, estimate the dissipation by interpolation. The estimation error is not critical.

2、 The chart is calculated for continuous current operation, if the actual operation is pulsed current, add 25% to 30% to the power dissipation of the average (RMS) current.

3、 When the Heat-Sink temperature reaches $\approx 85^{\circ}\text{C}$, the Gold Solo Twitter will shut down. Design the system for continuous operation so that the maximum Heat Sink temperature should be no higher than between 80°C to 82°C .

4、 If the average heat dissipation is less than $\approx 1.5\text{W}$ (operating 100W-150W motor) there will be no requirement for an additional external heat sink.

The above 1.5W is the net power conversion losses (excluding the control losses)

5、 If the average Heat dissipation is higher than 1.5W then an additional heat dissipation means is required, usually by connecting to an external heat-sink.

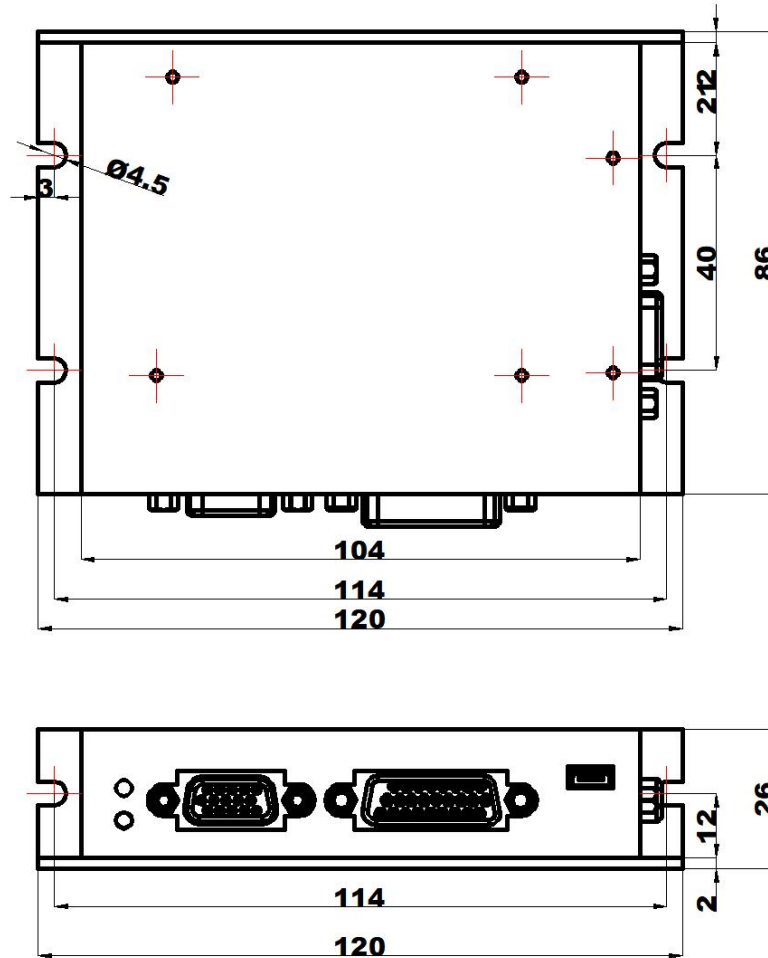
6、 When an external Heat-Sink is required, calculate the thermal resistance of the heat sink according to:

$$\theta_{c/w} = \frac{80^{\circ}\text{C} - T_{\text{Ambient}}}{\text{Heat Dissipation}}$$



Chapter9: Dimensions

This chapter provides detailed technical information regarding the G-BWHI xx/xx Standard.





Chapter9: Dimensions

This chapter provides detailed technical information regarding the G-DBWHI xx/xx Fins.

